

SYM	CHANGE NO	DATE	REV'D BY
/	1DT0030	'17. 9.25	K.Nakada
△	1DT0174 構成変更	'21.11.16	K.Nakada

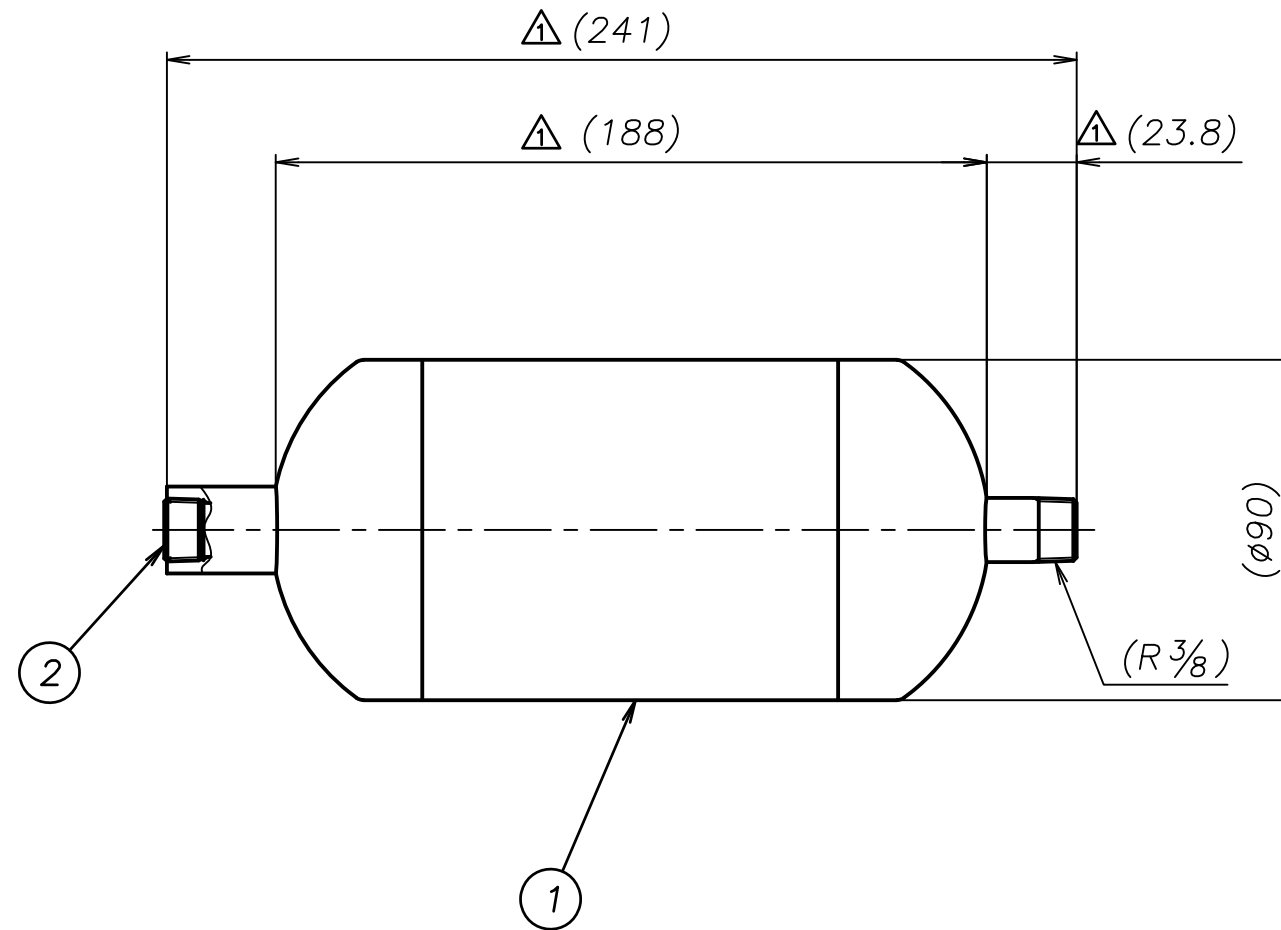

注1) (2) はシールテープで取付のこと
 *1) Apply seal tape around the threads of (2)

2	9P63P9903	プラグ PLUG	SUS316	R 3/8	1
△ 1	BY0662	ダンパ DAMPER	SUS316	R 3/8	1
REF. NO.	PART NO.	DESCRIPTION	MATERIAL	REMARKS	Q'TY
APP'D BY	'21.11.17 S.Murata	THE DWG. OF: ダンパ アッセンブリ DAMPER ASSEMBLY			
CHECKED BY	'21.11.17 K.Nakano	STS10			
DRAWN BY	'21.11.17 K.Nakada	THIRD ANG. PROJ. DWG.NO.			
YTS Co., Ltd JAPAN			SCALE Free	AH0881BE	