

SYM	DWG.NO	CHANGE NO	DATE	REV'D BY
	ALL	1DE0032	'22.12.12	K.Nakada

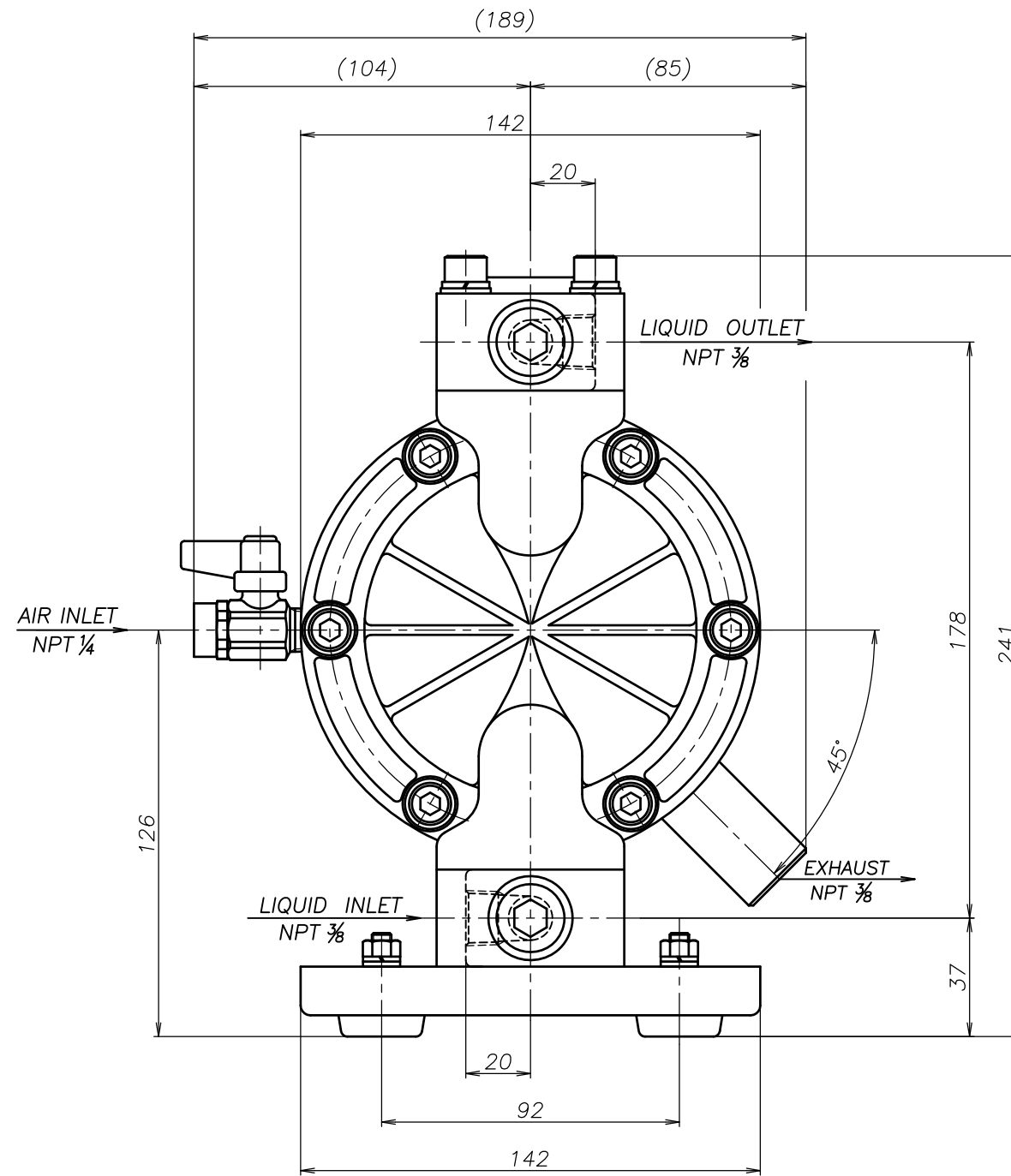
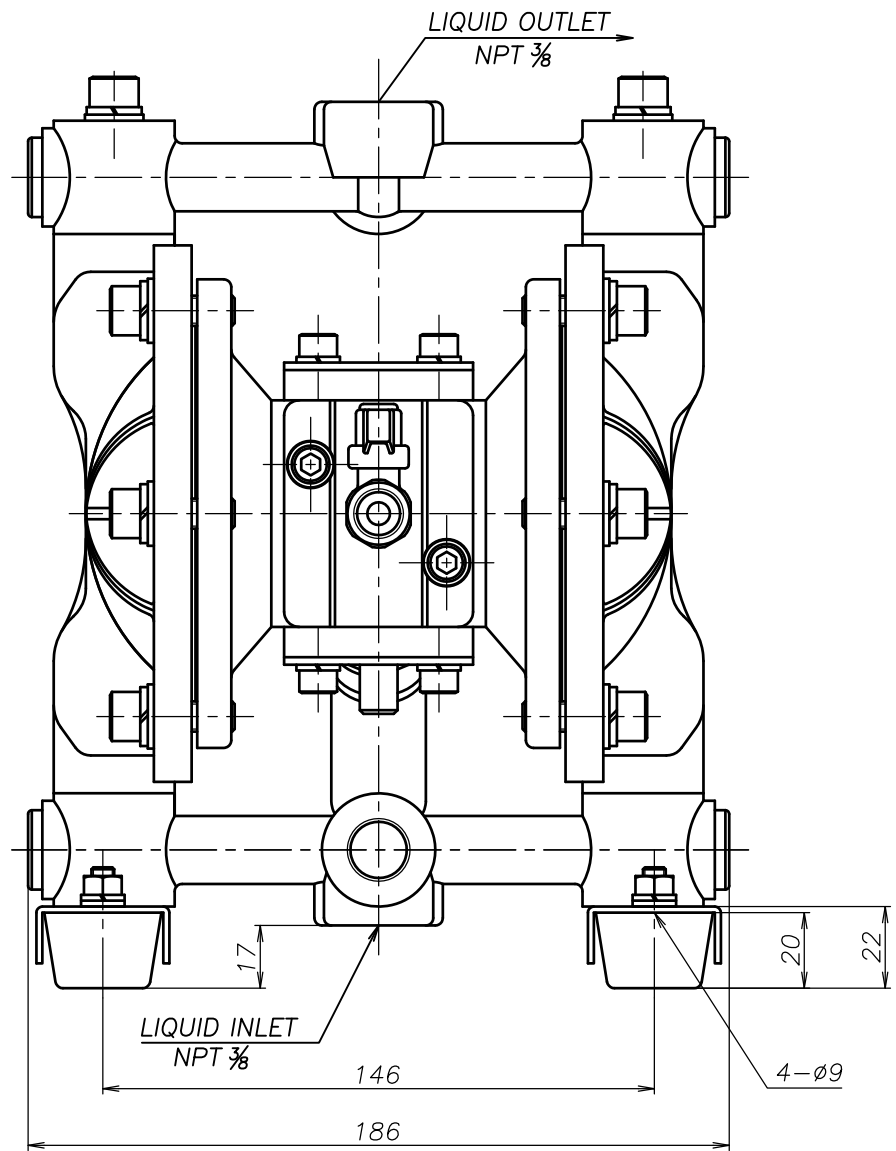

THE DWG. OF:  
ダイアフラムポンプアッセンブリ  
DIAPHRAGM PUMP ASSEMBLY  
101 ASN  
THIRD ANG. PROJ. DWG.NO.  
SCALE Free 1D00034YN-A

THE DWG. OF:  
ダイアフラムポンプアッセンブリ  
DIAPHRAGM PUMP ASSEMBLY  
101 AHN  
THIRD ANG. PROJ. DWG.NO.  
SCALE Free 1D00033YN-A

THE DWG. OF:  
ダイアフラムポンプアッセンブリ  
DIAPHRAGM PUMP ASSEMBLY  
101 ATN  
THIRD ANG. PROJ. DWG.NO.  
SCALE Free 1D00032YN-A

THE DWG. OF:  
ダイアフラムポンプアッセンブリ  
DIAPHRAGM PUMP ASSEMBLY  
101 ANN  
THIRD ANG. PROJ. DWG.NO.  
SCALE Free 1D00031YN-A

APP'D BY	'24. 3.29	S.Murata	THE DWG. OF: ダイアフラムポンプアッセンブリ DIAPHRAGM PUMP ASSEMBLY
CHECKED BY	'24. 3.29	Y.Takahashi	101 ACN
DRAWN BY	'24. 3.29	J.Tomatsuri	THIRD ANG. PROJ. DWG.NO. SCALE Free 1D00030YN-A
<b>YTS</b> Co., Ltd JAPAN			