

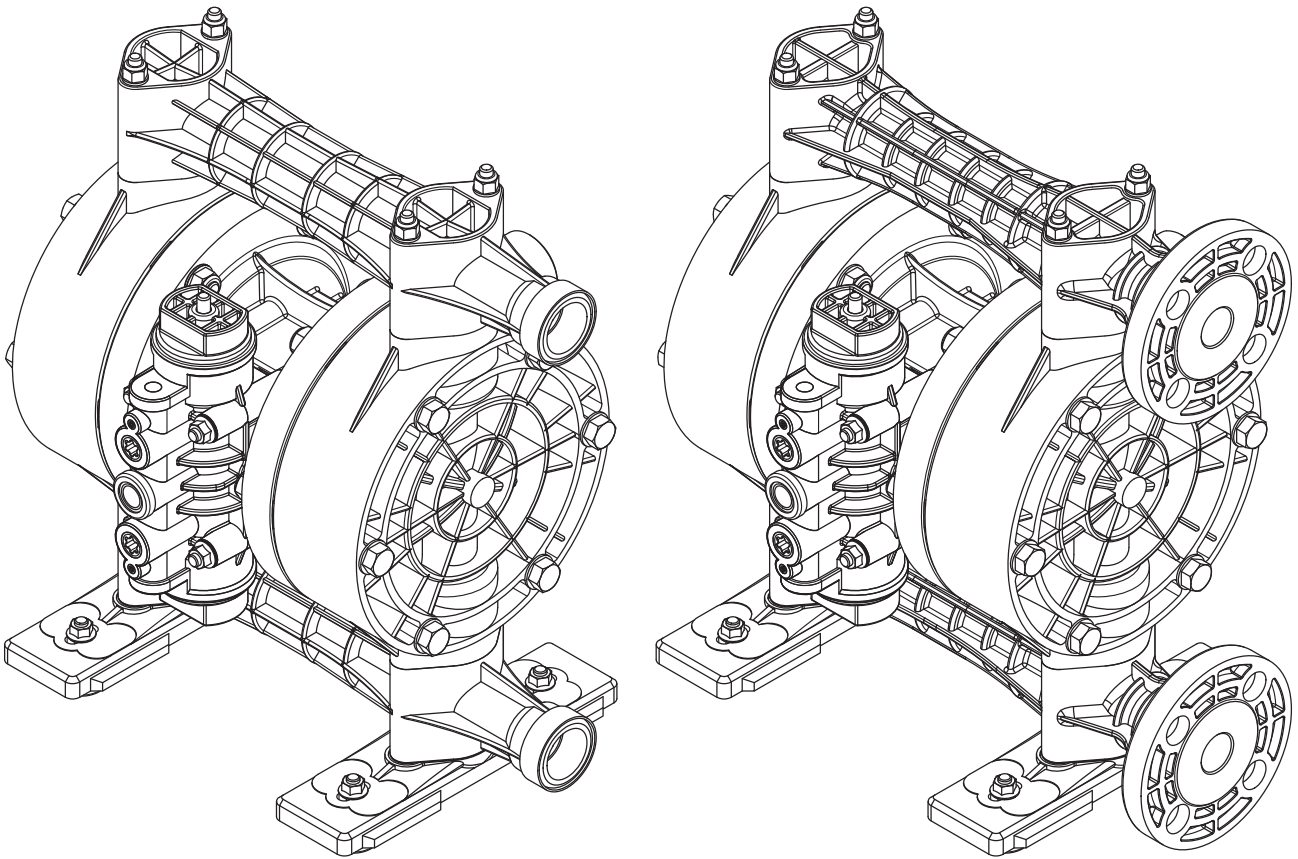

PUMP SERVICE BOOK



D200G D200V D250G D250V D250C
Series Pumps

HOW TO USE THE PUMP SERVICE BOOK

D200GV D250GV Series Pumps

- The servicing method for each pump can be different depending on the model and size. Please refer to the "Model Name" noted on the Pump Identification Plate and use the below table as a page number and diagram reference guide.

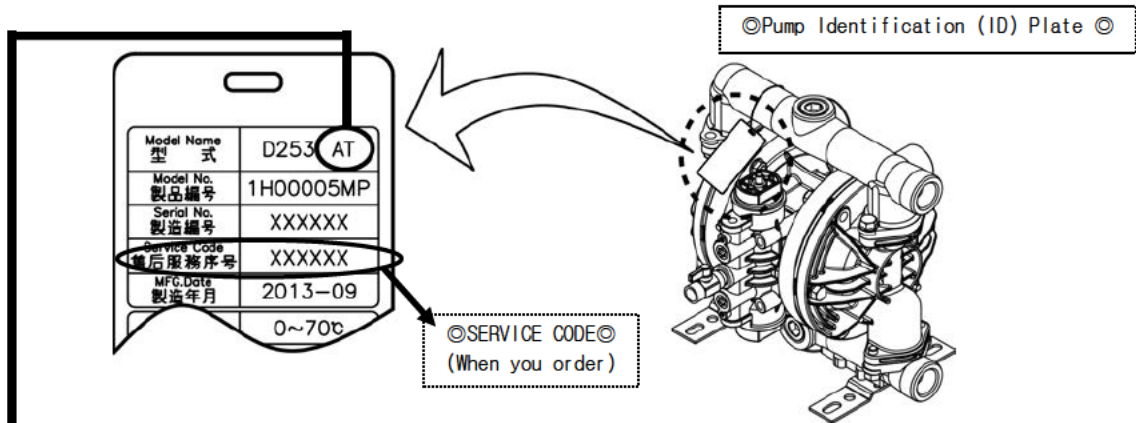

	· BALL · VALVE SEAT · FLAT VALVE	· DIAPHRAGM · CENTRE DISK	· CENTRE DISK · DIAPHRAGM · Mounting Direction	· THROAT BEARING · PILOT VALVE	· C SPOOL ASSEMBLY · SPOOL ASSEMBLY	· Exploded View ※ 1 · Assembly torque values / Re-torque values
Pump Model Code	Page Number & Diagram Reference Numbers					
GC GN GE GV VE VV CC CN CE CV	1-①(200) 1-②(250)	2	3-①	4	5	6-①(200) 6-②(250)
GH GS VH VS CH CS	1-①(200) 1-②(250)	2	3-②	4	5	6-①(200) 6-②(250)
GT VT CT	1-①(200) 1-②(250)	2	3-③	4	5	6-①(200) 6-②(250)

※ 1) Before operating the pump for the first time please re-torque all bolts. Also re-torque bolts if leaks are discovered as part of the daily inspection regime.

Description of Diagrams used within the Pump Service Book

	Check Condition & Measurements Carefully		Use Oil to help with Assembly		Use Grease to help with Assembly
	If within tolerance then continue to Use		If beyond allowable tolerance then dispose		Replace with New Parts

⚠ WARNING



For your own safety and the safety of the people around you, be sure to read the procedures noted within carefully before performing maintenance on this product. After reading this document, be sure to keep it handy for future reference.

⚠ WARNING



Before commencing any maintenance work, Disconnect the compressed air supply and remove and clean any remaining liquids contained on around or within the pump. If liquids are not removed or neutralized then there is a possibility of a serious injury such as burns, blindness, poisoning or even death if chemicals adhere to the skin eyes or are accidentally inhaled or swallowed. If residual air pressure is present within the pump there could be a danger of sudden decompression or explosion resulting in severe injury or even death. In case of disassembling, be sure to wear protective equipment, such as face mask, gloves, etc. When replacing spare parts, be sure to use genuine YTS parts. The installation and use of non-specified parts may cause a malfunction or damage to the product.

Service Tools

Ⓐ Sleeve Puller Tool And PP Wrench (Can be purchased separately)

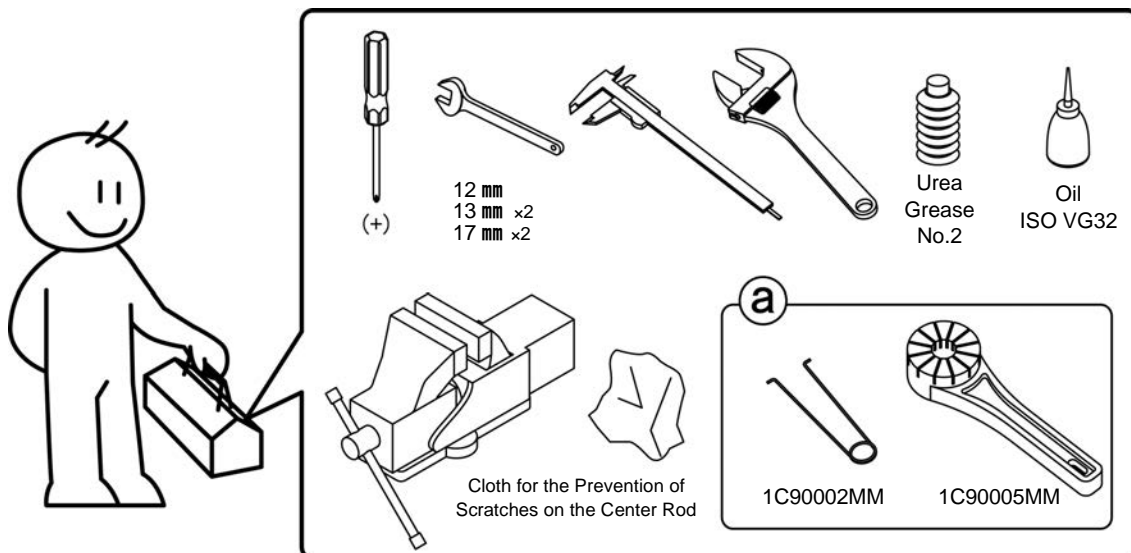

Recommended Changeover Time for the Replacement of Diaphragms ※

CR, NBR, EPDM	10 million cycles
FKM	2.5 million cycles
PTFE	3 million cycles
TPEE, TPO	15 million cycles

- ※ Conditions; with fresh water at room temperature and 0 head
Conditions such as over pressurization, dry running high or low temperatures, Chemical attack or Abrasion etc. can drastically shorten diaphragm life.
- ※ O-rings and packing should be replaced during service.
- ※ When reassembling the pump please follow the disassembly Procedure in reverse. For all torque values refer to the Exploded view on page 6.
- ※ When ordering spare parts, please refer to the pump "SERVICE CODE". As stated on the Identification plate.

YTS Japan Co., Ltd reserves the right to change pump specifications at any time without notice.

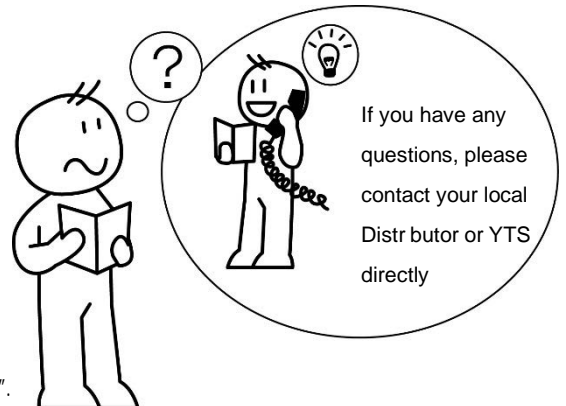

1-① (200)GC GN GE GV GH GS GT VE VV VT VH VS

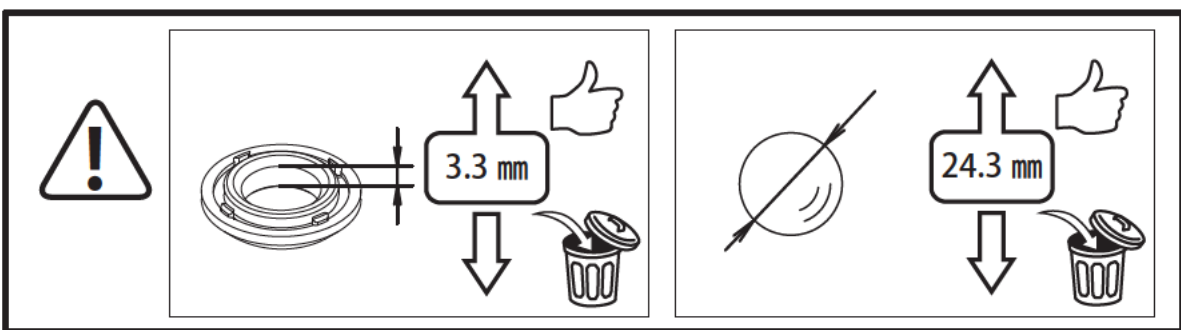
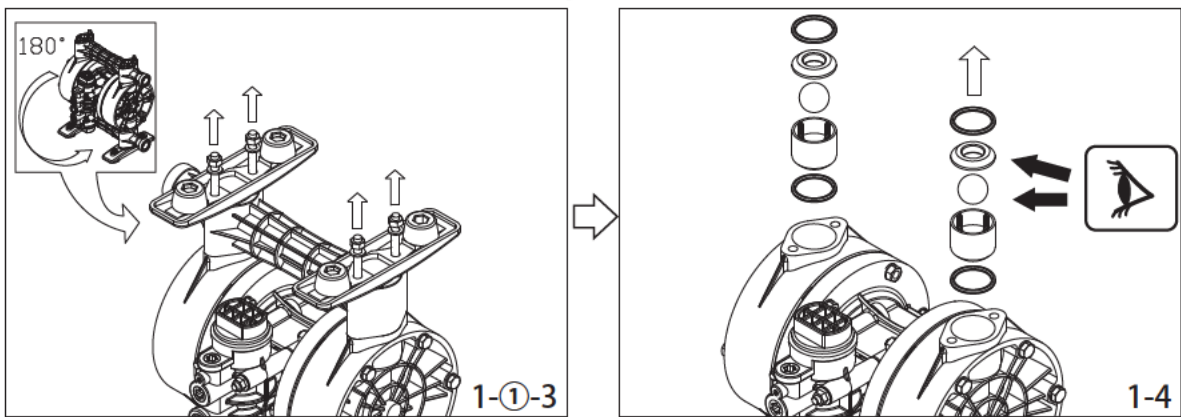
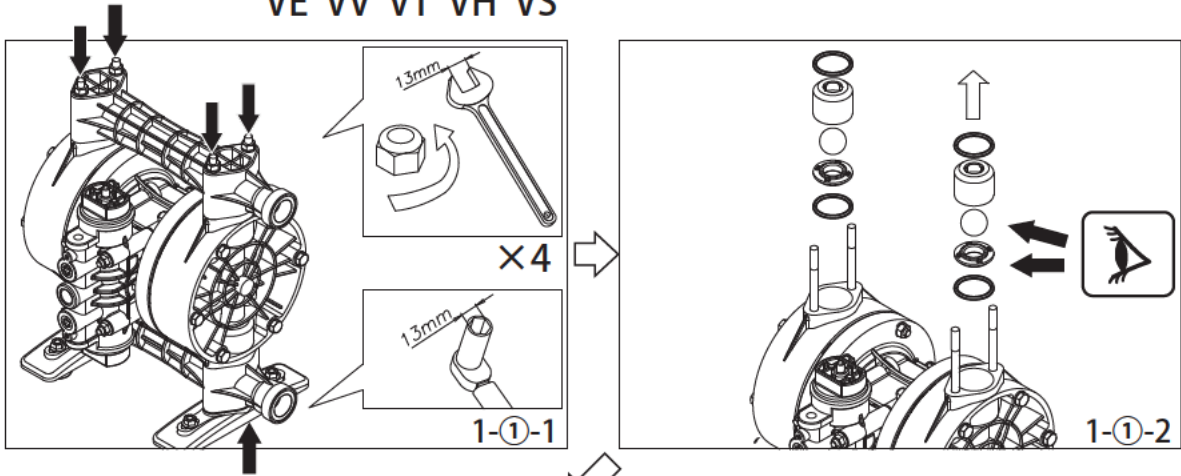

1

1-② (250) GC GN GE GV GH GS GT
VE VV VT VH VS
CC CN CE CV CT CH CS

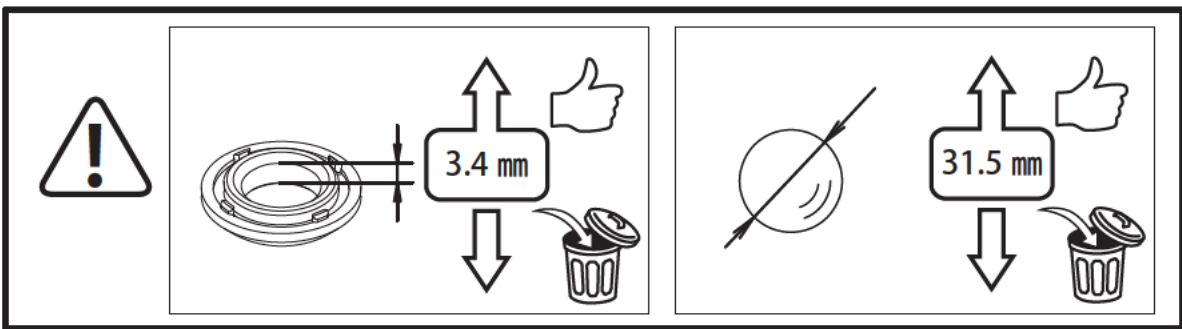
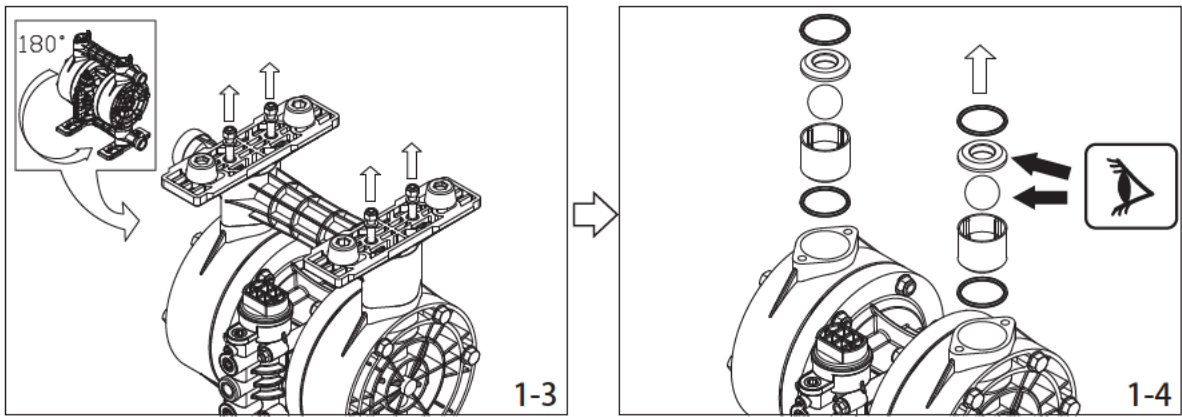
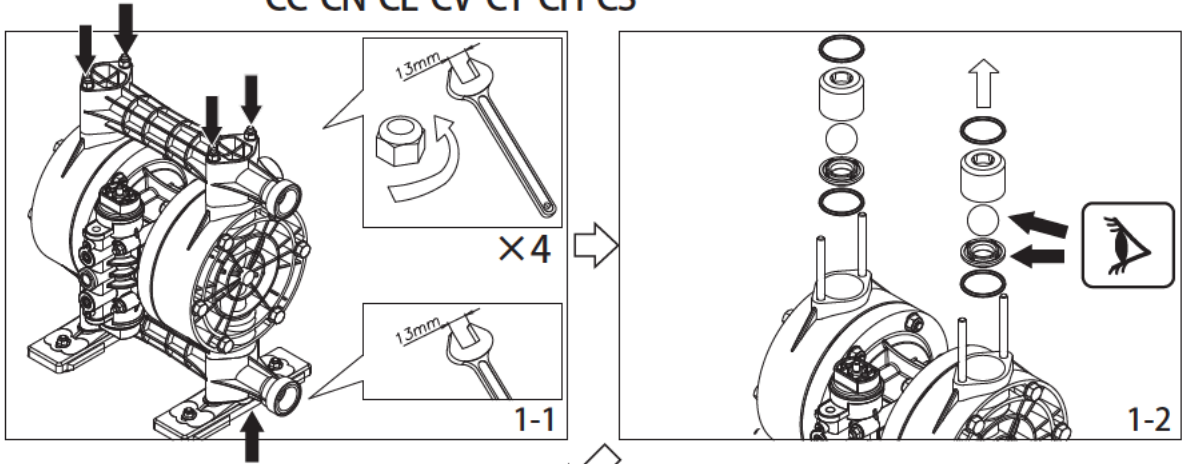

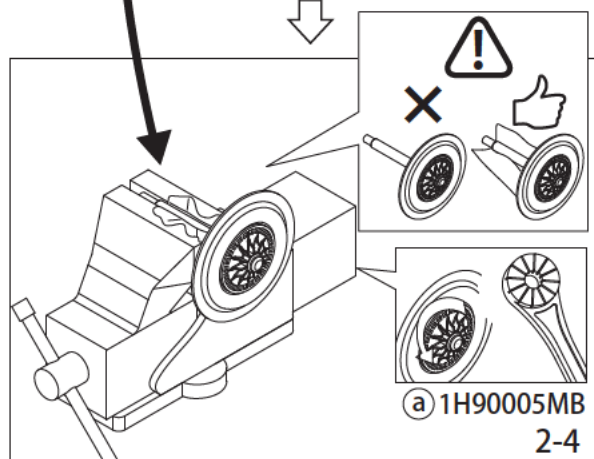
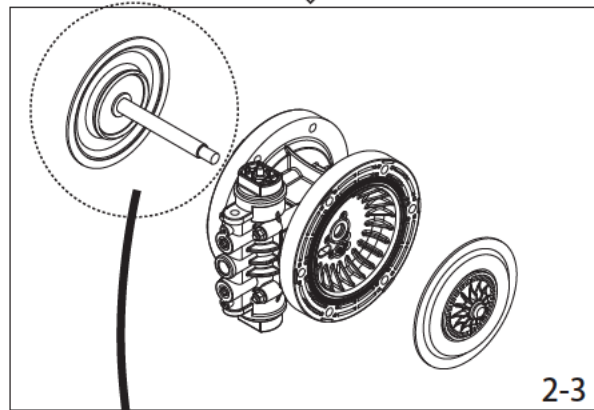
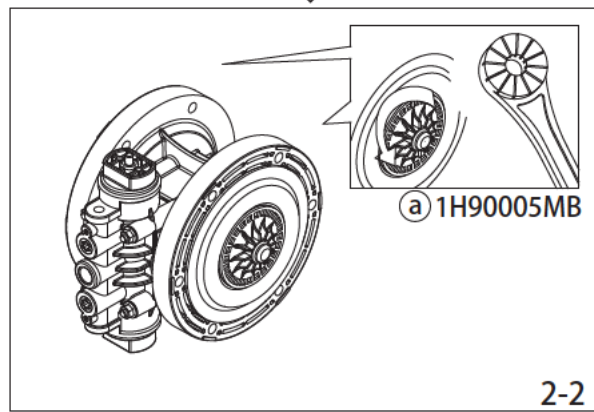
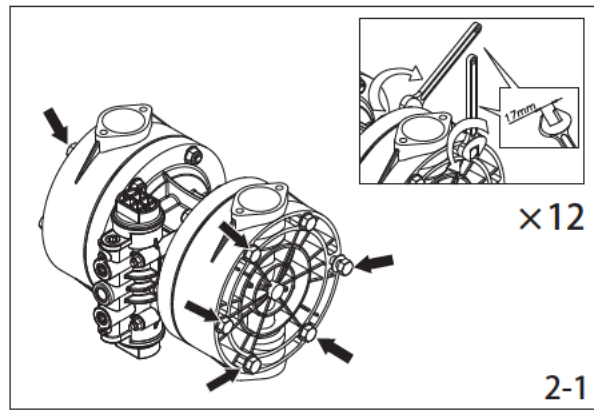

3

3-①

GC VE CC
 GN VV CN
 GE CE
 GV CV

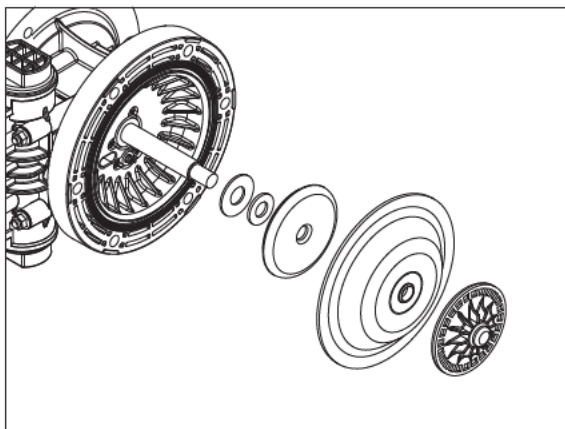

3-②

GH VH CH
 GS VS CS

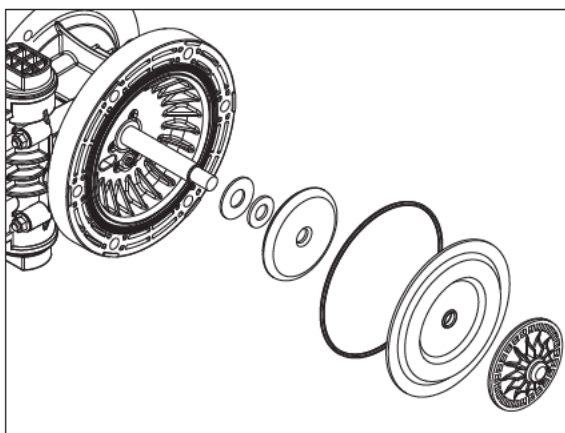

3-③

GT VT CT

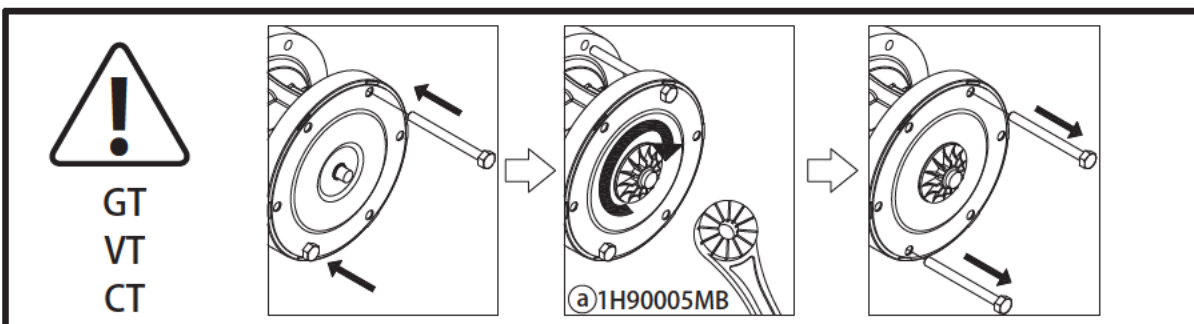
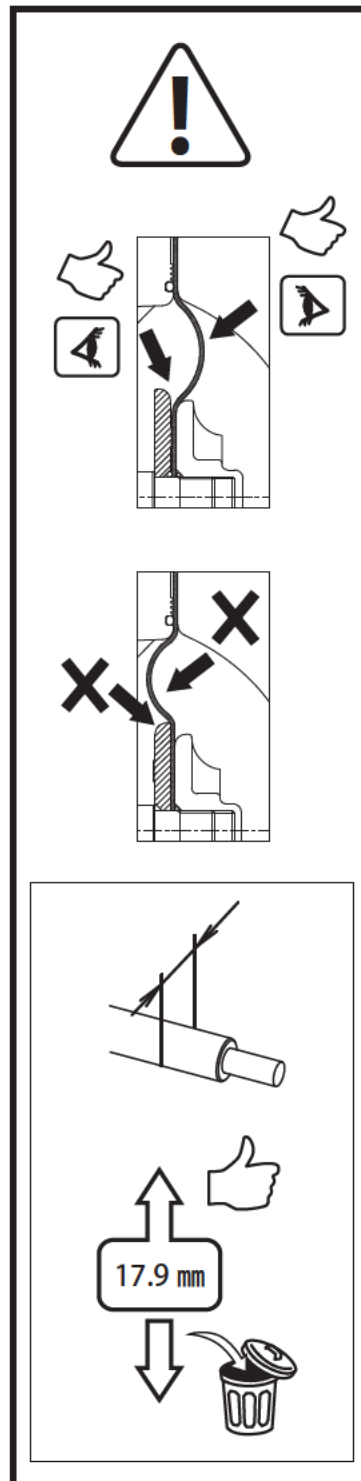
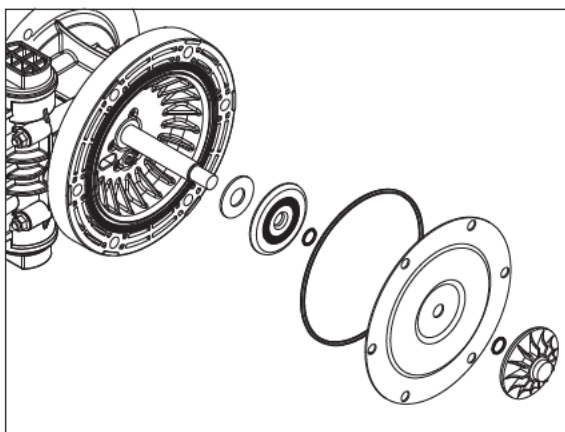

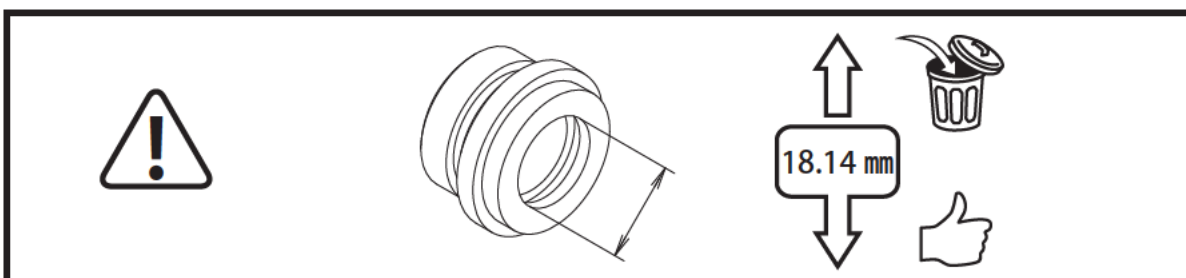
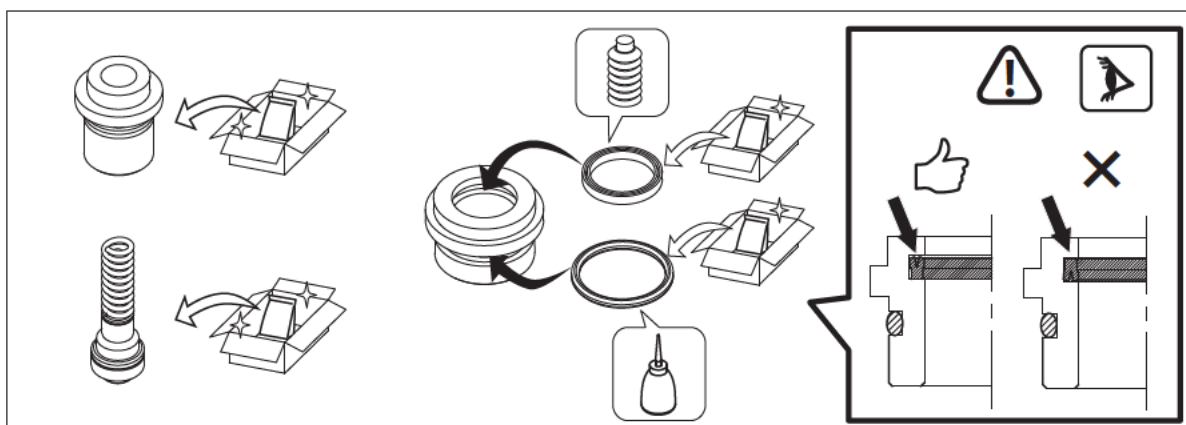
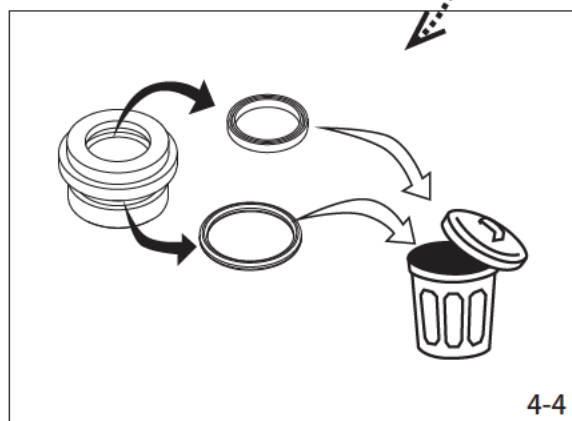
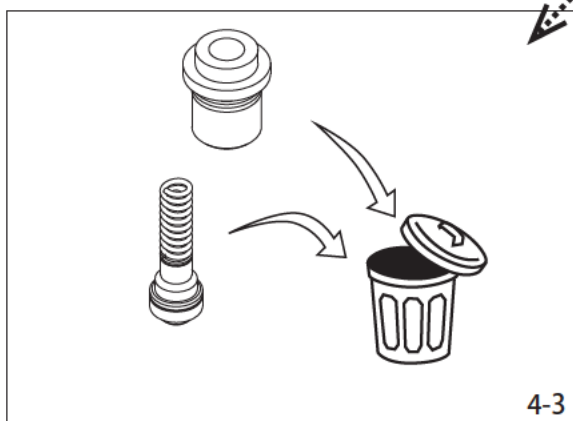
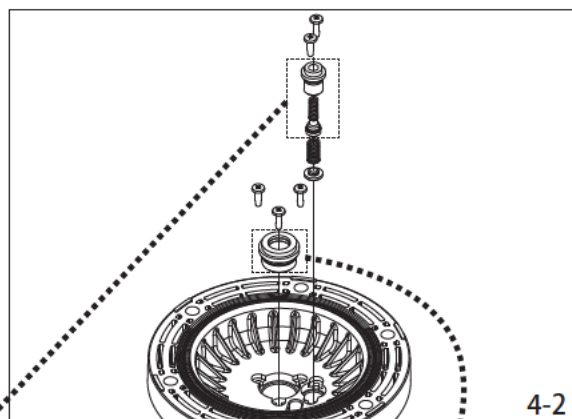
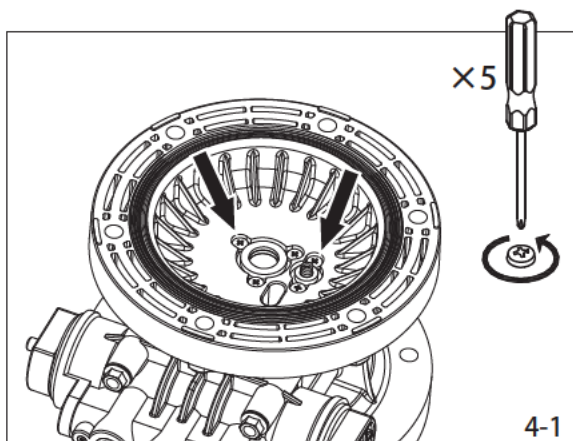

5

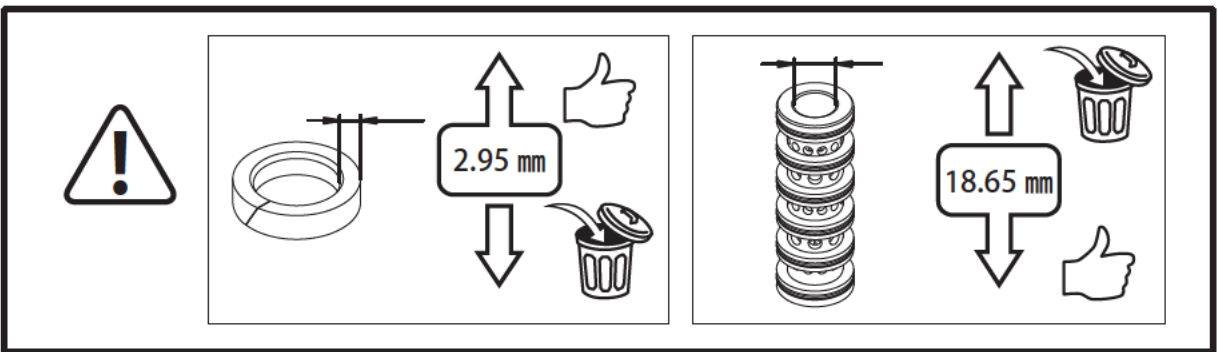
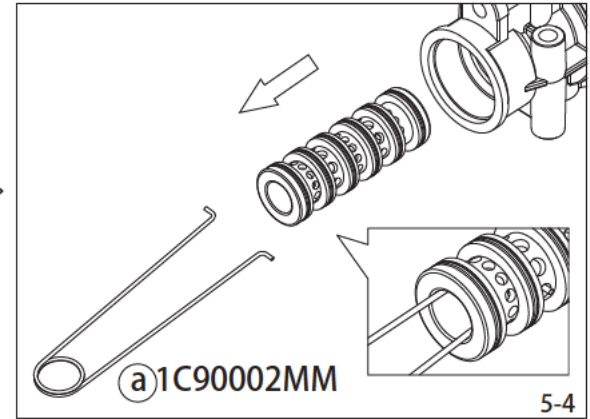
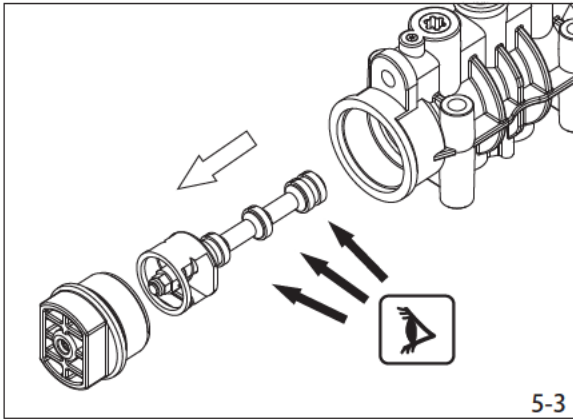
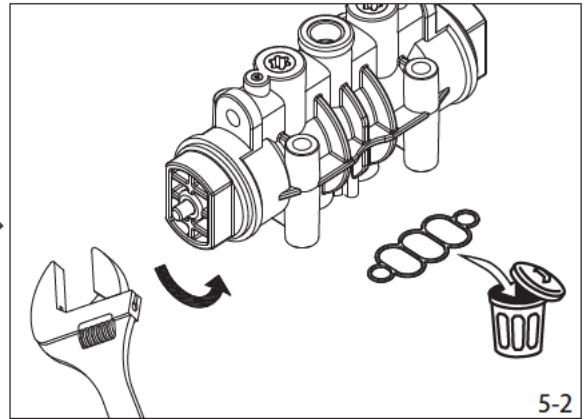
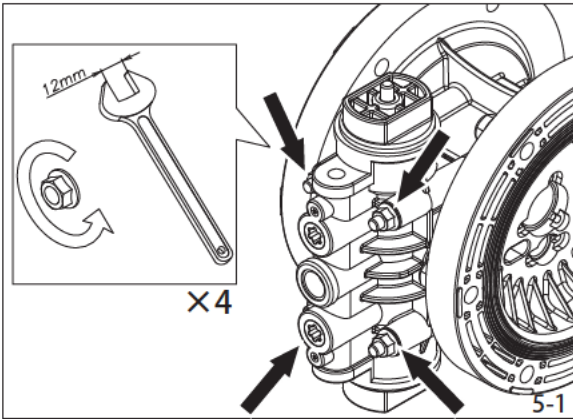

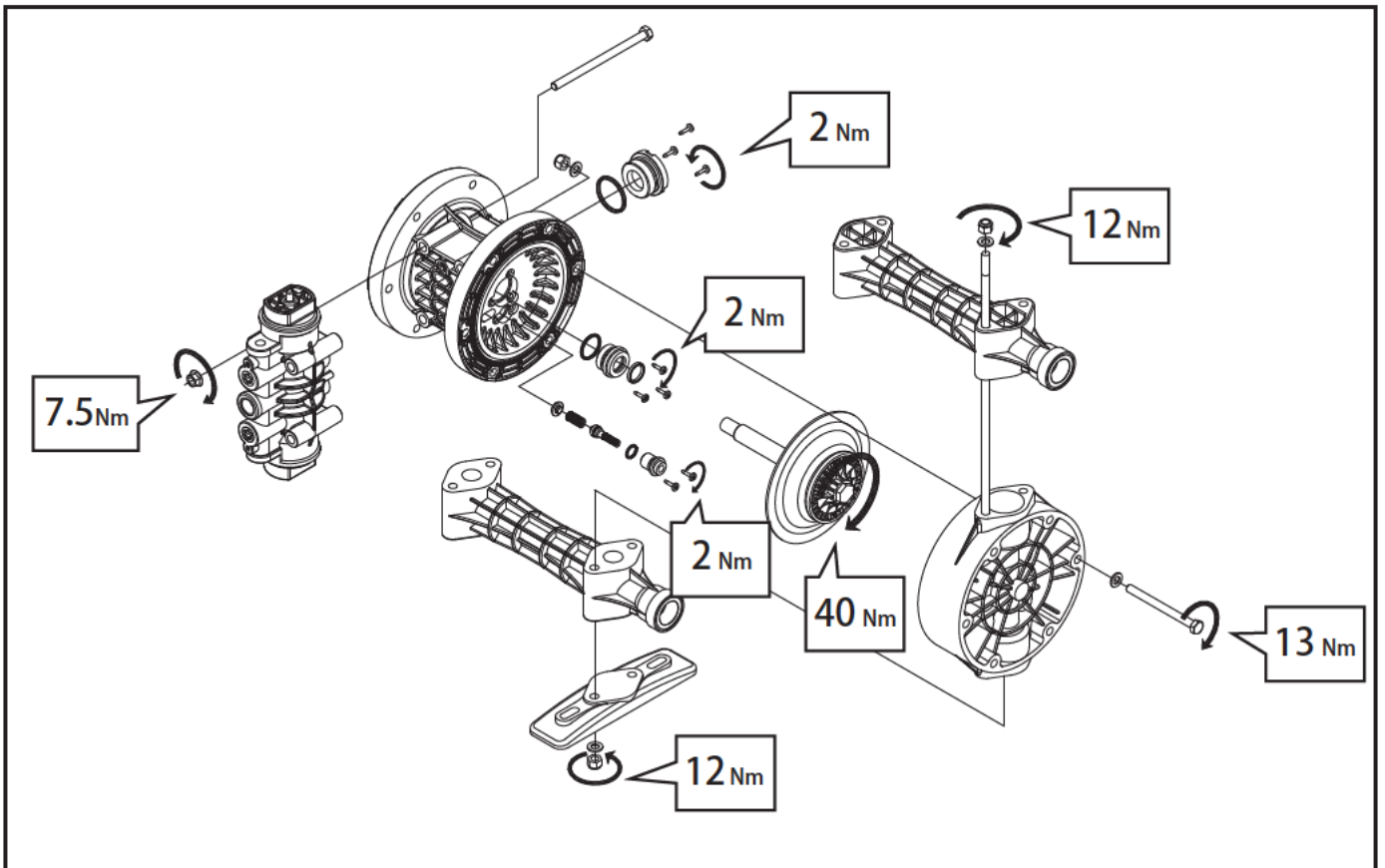
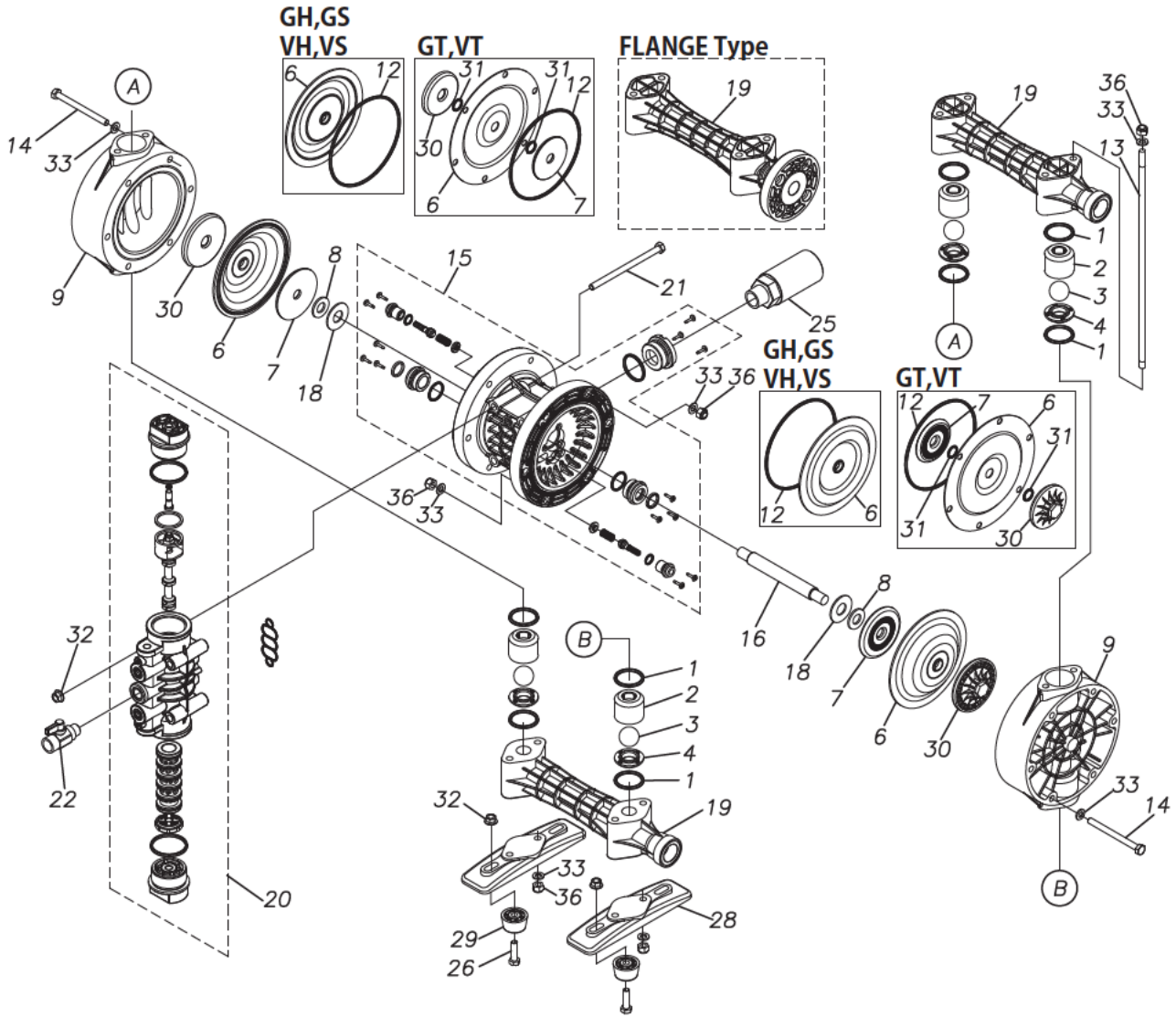

6

250G □ 250V □ 250C □

6-2

