

SYM	DWG.NO	CHANGE NO	DATE	REV'D BY
△	ALL	1EE0009	'14.12.18	K.Nakada
△	ALL	1EE0019	'11.11.05	K.Nakano
△	ALL	1BE0005	'19.10.28	K.Nakada

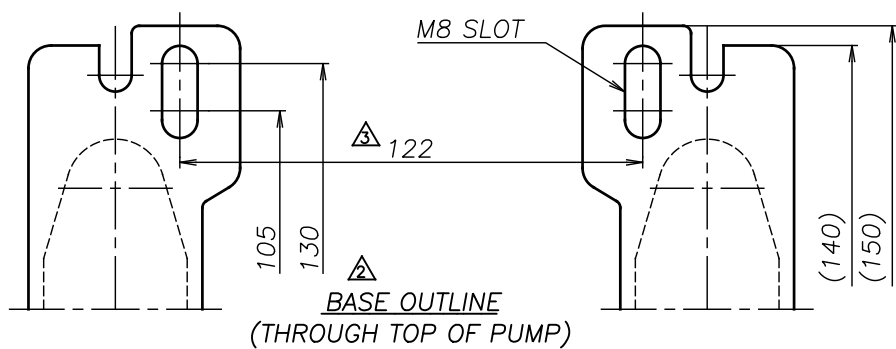
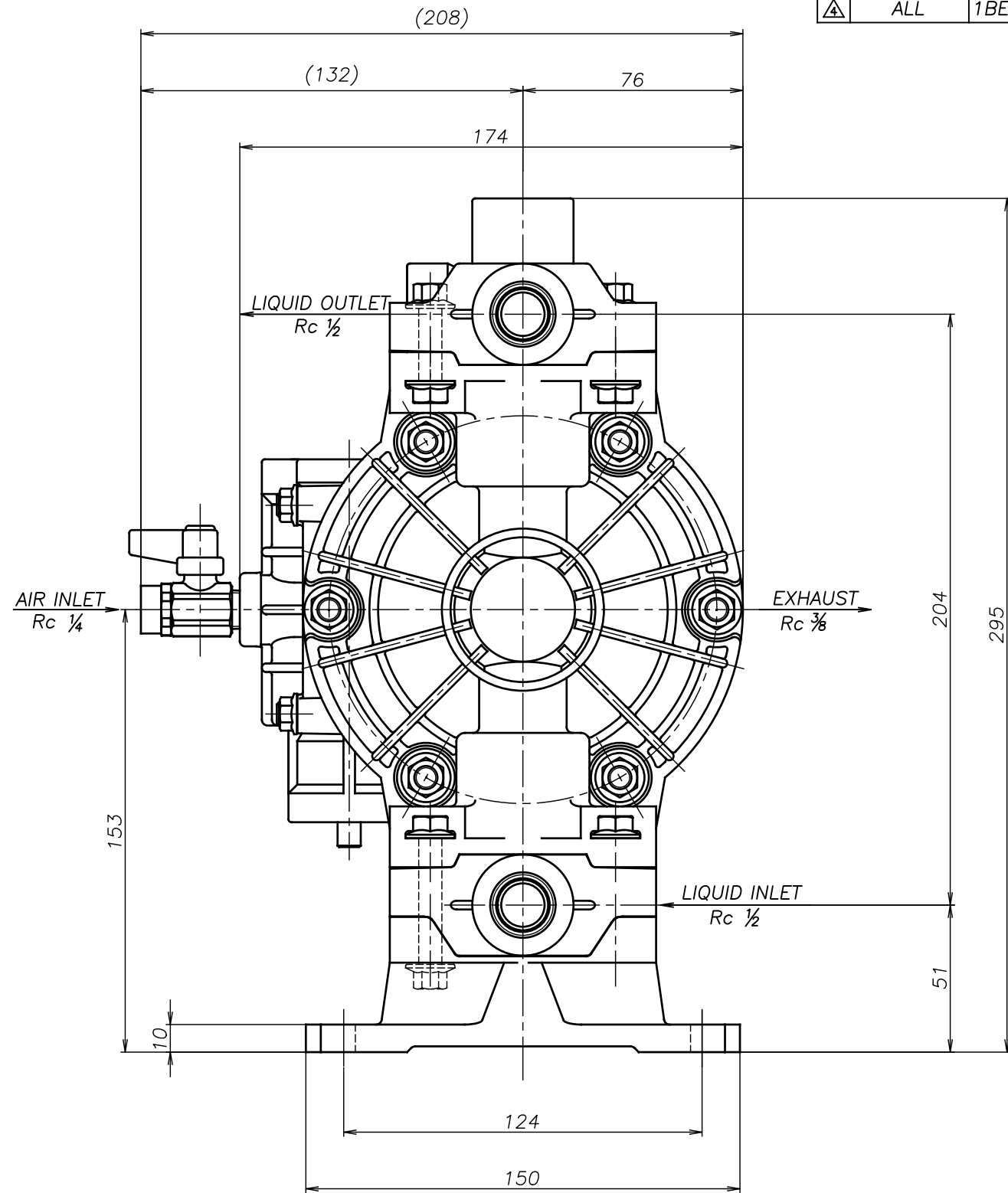
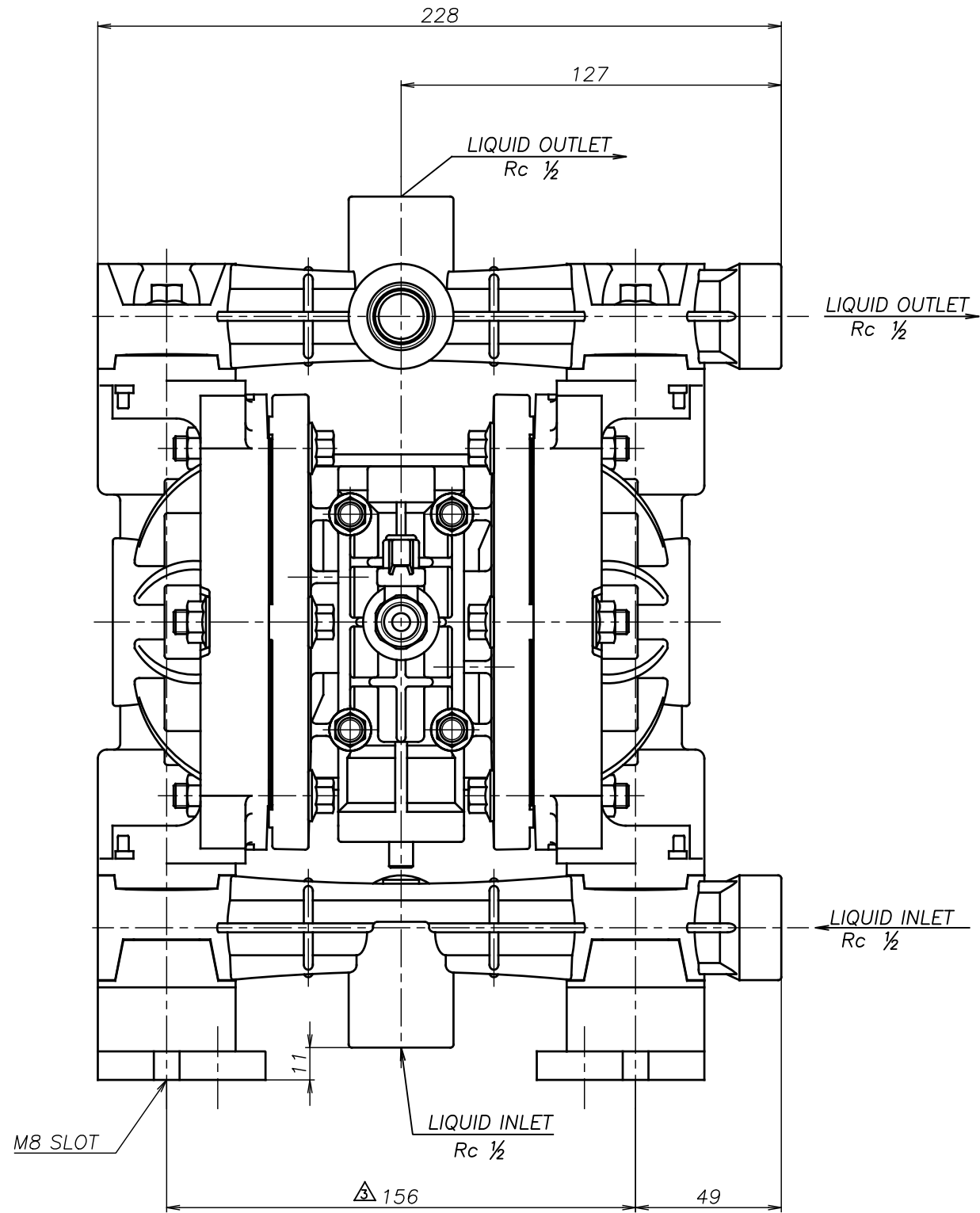

APP'D BY '20, 5.21 S.Murata
 CHECKED BY '20, 5.21 S.Murata
 DRAWN BY '20, 5.21 K.Nakano

YTS Co., Ltd JAPAN

△152 VS	DWG.NO.	1E00017YP-E
THIRD ANG. PROJ.	SCALE	Free
THE DWG. OF: ダイヤフラムポンプアセンブリ		
DIAPHRAGM PUMP ASSEMBLY		
△152 VT	DWG.NO.	1E00016YP-E
THIRD ANG. PROJ.	SCALE	Free