

SYM	DWG.NO	CHANGE NO	DATE	REV'D BY
△	ALL	1LE0005	'16. 3. 3	K.Nakada
△	ALL	1BE0005	'19.10.28	K.Nakada
△	ALL	1BE0006 異記訂正	'20. 6.23	K.Nakada

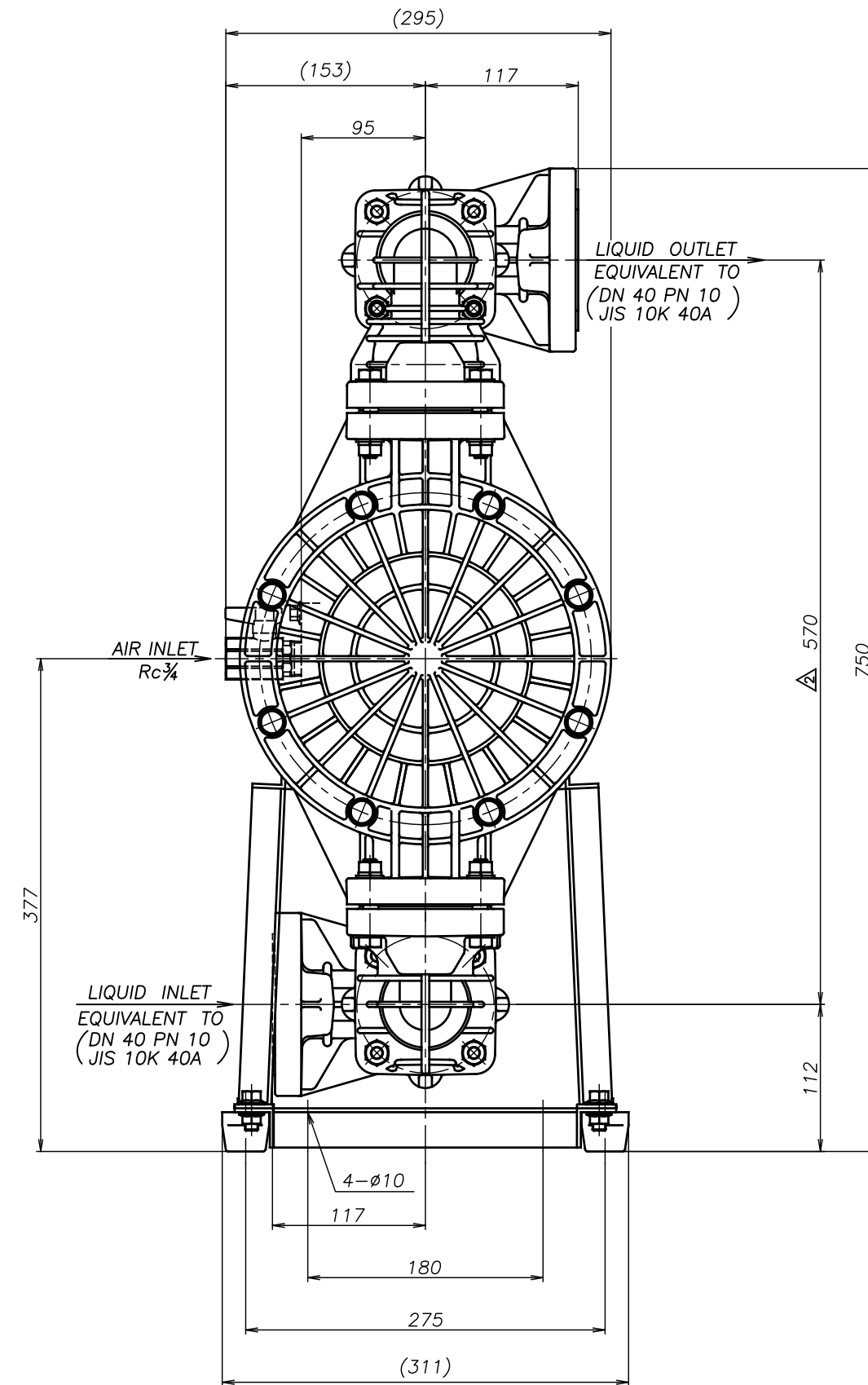
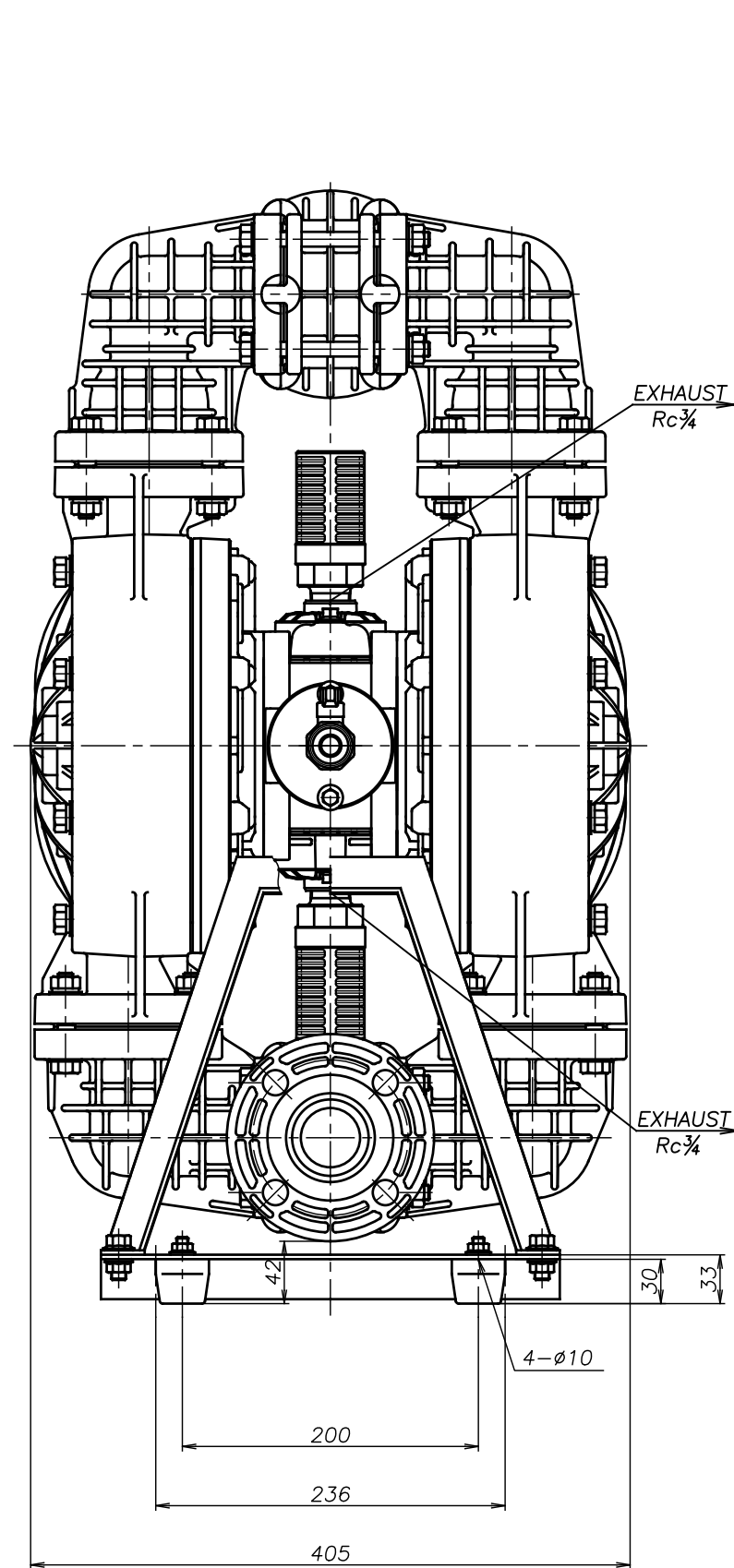

△400 GSJ-M	THIRD ANG. PROJ.	DWG.NO.
	SCALE	Free 1L00007YP-C
△400 GHJ-M	THIRD ANG. PROJ.	DWG.NO.
	SCALE	Free 1L00006YP-C
△400 GTJ-M	THIRD ANG. PROJ.	DWG.NO.
	SCALE	Free 1L00005YP-C
△400 GVJ-M	THIRD ANG. PROJ.	DWG.NO.
	SCALE	Free 1L00004YP-C
△400 GEJ-M	THIRD ANG. PROJ.	DWG.NO.
	SCALE	Free 1L00003YP-C
△400 GNJ-M	THIRD ANG. PROJ.	DWG.NO.
	SCALE	Free 1L00002YP-C

APP'D BY	'20. 6.23	S.Murata	THE DWG. OF:
CHECKED BY	'20. 6.23	K.Nakano	ダイアフラムポンプアセンブリ
DRAWN BY	'20. 6.23	K.Nakada	DIAPHRAGM PUMP ASSEMBLY
			△400 GCJ-M
			THIRD ANG. PROJ.
			DWG.NO.
			SCALE
			Free 1L00001YP-C

YTS Co., Ltd JAPAN