

SYM	DWG.NO	CHANGE NO	DATE	REV'D BY
△	ALL	1ME0023	'18. 1.16	K.Sugaya
△	ALL	1BE0005	'19.10.28	K.Nakada
△	ALL	1BE0006 異記訂正	'20. 6.23	K.Nakada

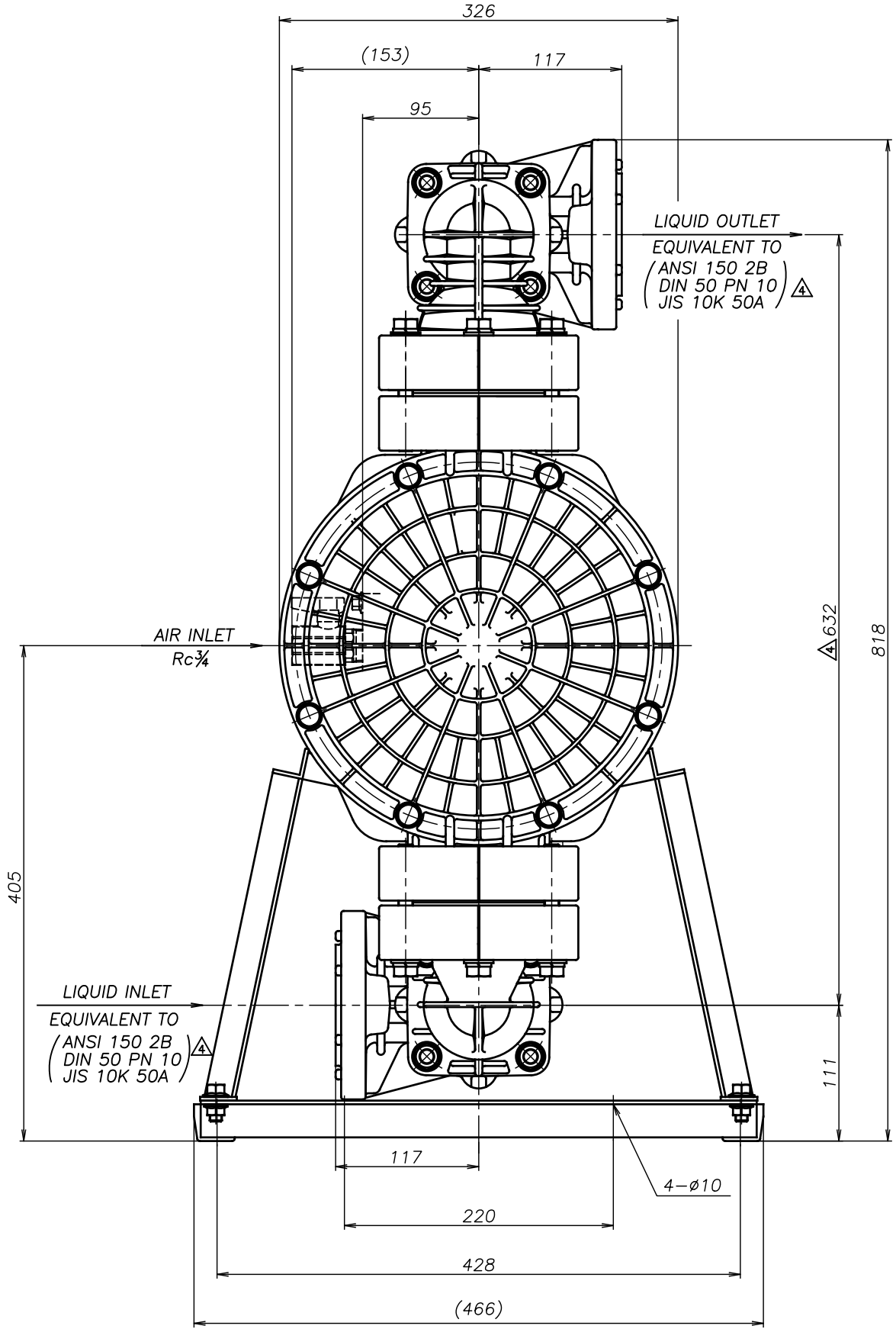
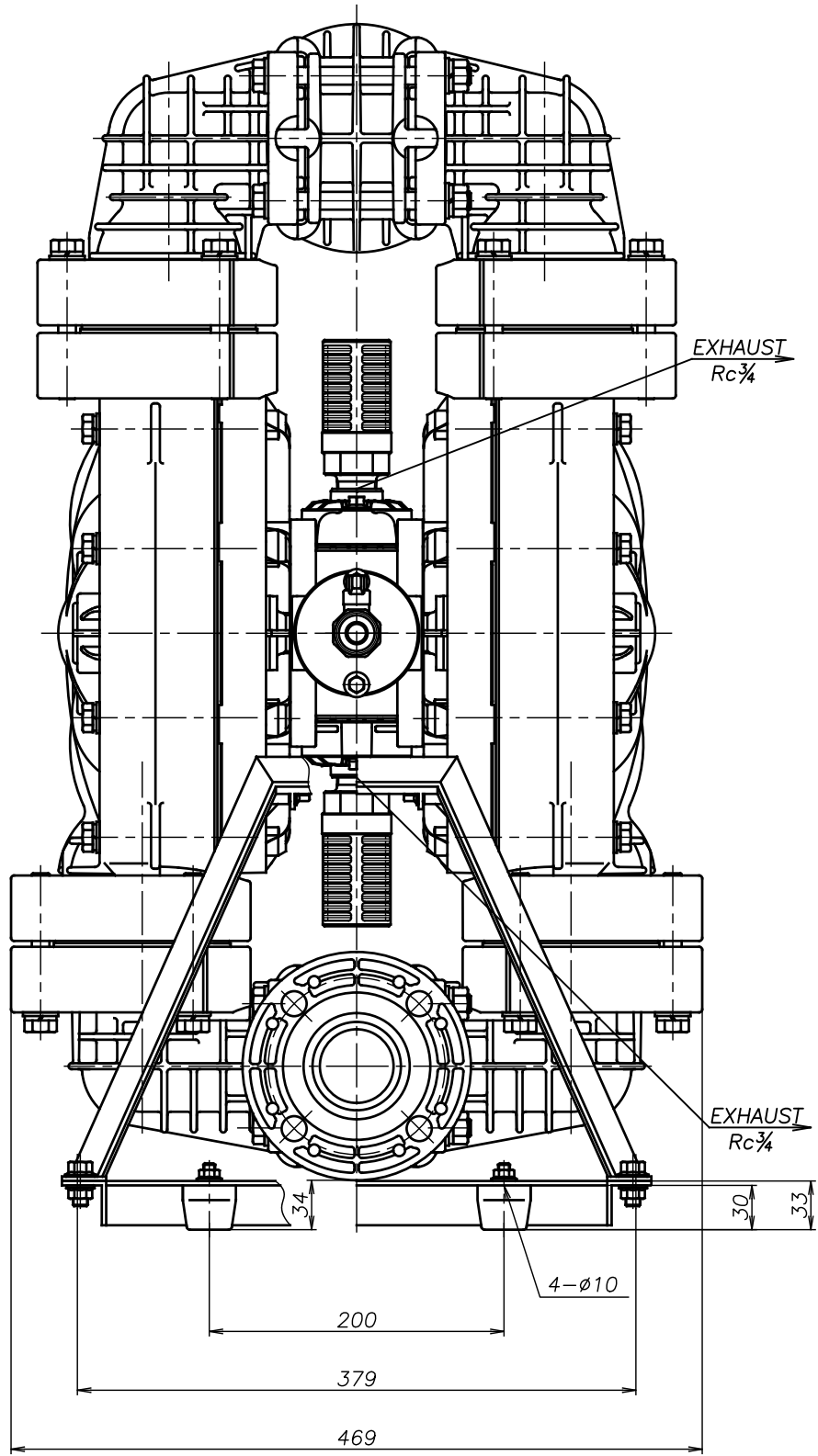

△△500 GSJ-M	THIRD ANG. PROJ.	DWG.NO.
	SCALE Free	1M00035YP-E
△△500 GHJ-M	THIRD ANG. PROJ.	DWG.NO.
	SCALE Free	1M00034YP-E
△△500 GTJ-M	THIRD ANG. PROJ.	DWG.NO.
	SCALE Free	1M00033YP-E
△△500 GVJ-M	THIRD ANG. PROJ.	DWG.NO.
	SCALE Free	1M00032YP-E
△△500 GEJ-M	THIRD ANG. PROJ.	DWG.NO.
	SCALE Free	1M00031YP-E
△△500 GNJ-M	THIRD ANG. PROJ.	DWG.NO.
	SCALE Free	1M00030YP-E

APP'D BY '20. 6.23	S.Murata	THE DWG. OF:
CHECKED BY '20. 6.23	K.Nakano	ダイヤフラムポンプアセンブリ
DRAWN BY '20. 6.23	K.Nakada	DIAPHRAGM PUMP ASSEMBLY
		△△500 GCJ-M
		THIRD ANG. PROJ.
		DWG.NO.
		SCALE Free
		1M00029YP-E

YTS Co., Ltd JAPAN