

SYM	DWG.NO	CHANGE NO	DATE	REV'D BY
△	ALL	1EE0023	'16. 6.16	S.Murata
△	ALL	1BE0005	'19.10.28	K.Nakada
△	ALL	1BE0006 異記訂正	'20. 6.23	K.Nakada

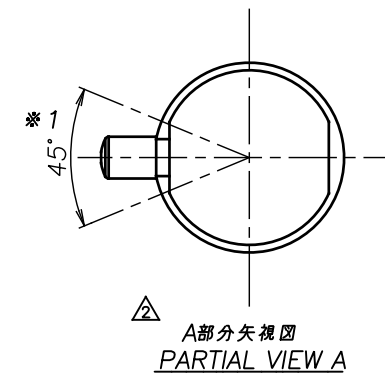
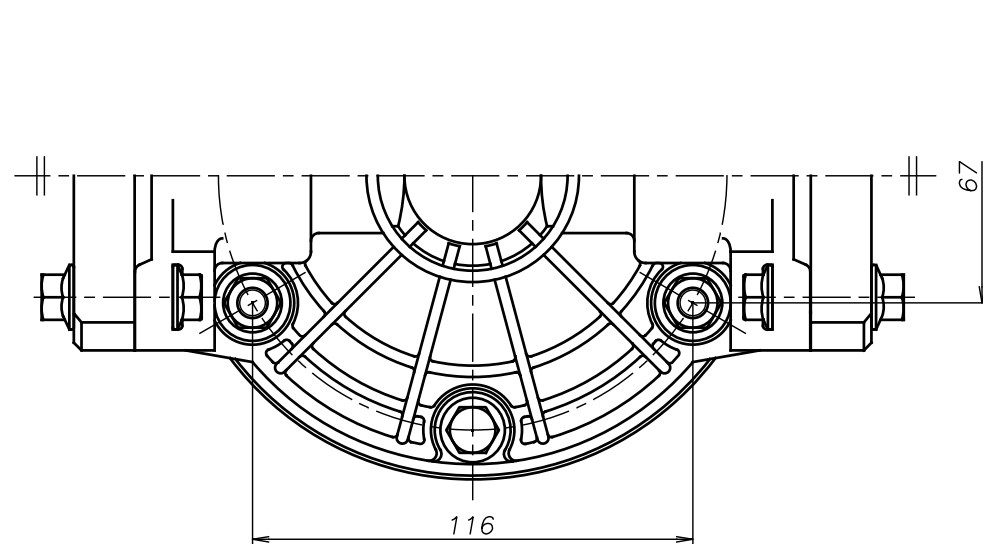
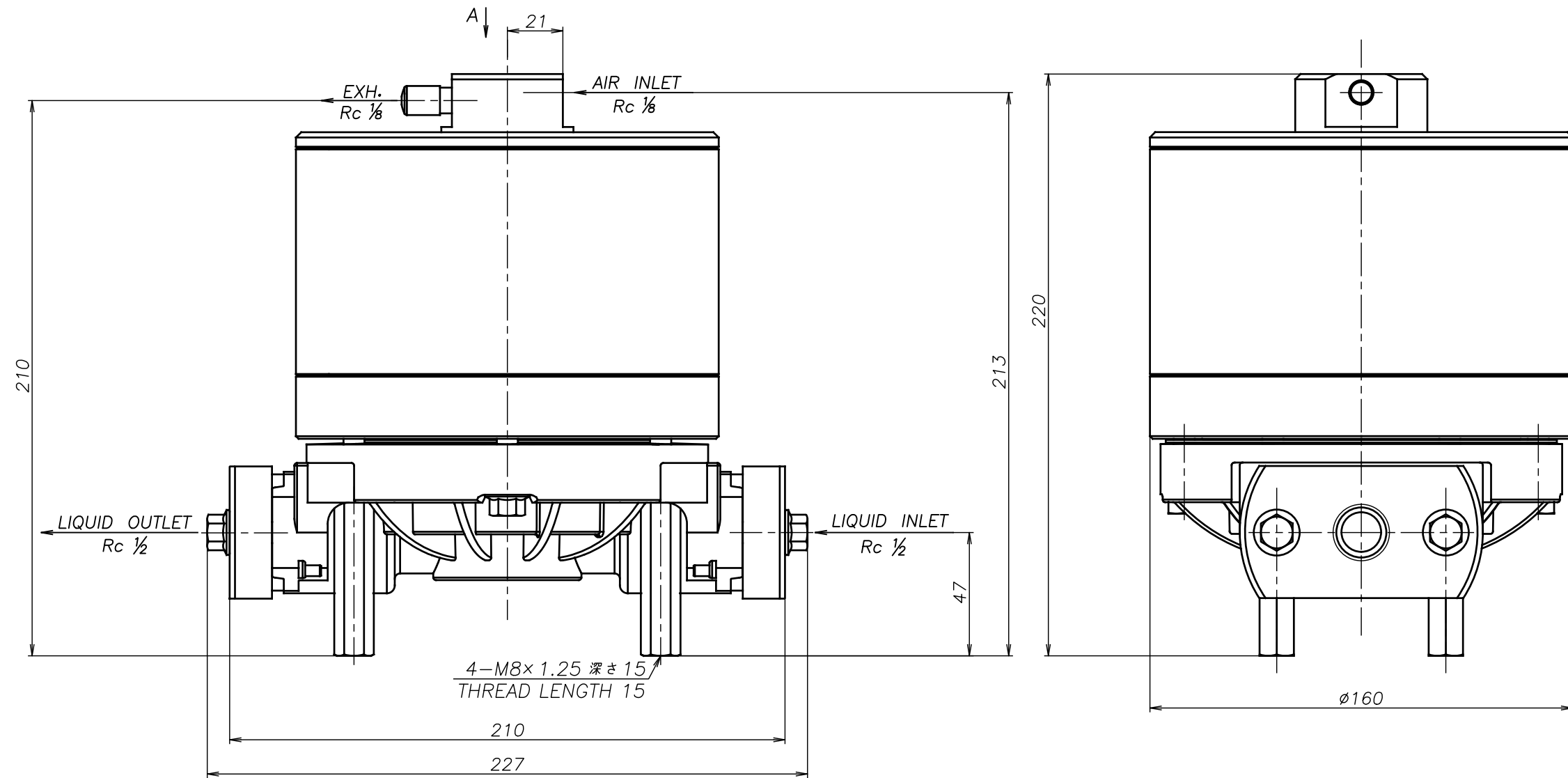

△ 注1) AIR INLET, EXH.は ※1 の範囲で固定されています
 △ NOTE:1) AIR INLET & EXH. port are fixed in the range of ※1.

△15 PS	THIRD ANG. PROJ.	DWG.NO.	1E00158YP-C
△15 PH	THIRD ANG. PROJ.	DWG.NO.	1E00157YP-C
△15 PT	THIRD ANG. PROJ.	DWG.NO.	1E00156YP-C
△15 PN	THIRD ANG. PROJ.	DWG.NO.	1E00155YP-C
△15 PC	THIRD ANG. PROJ.	DWG.NO.	1E00154YP-C

APP'D BY '20. 6.23 S.Murata
 CHECKED BY '20. 6.23 K.Nakano
 DRAWN BY '20. 6.23 K.Nakada

THE DWG. OF:
 ダンパアセンブリ
 DAMPER ASSEMBLY

YTS Co., Ltd JAPAN