

SYM	DWG.NO	CHANGE NO	DATE	REV'D BY
△	ALL	1LE0035	'18. 9. 3	K.Nakada
△	ALL	1BE0005	'19.10.28	K.Nakada
△	ALL	1BE0006 異記訂正	'20. 6.23	K.Nakada

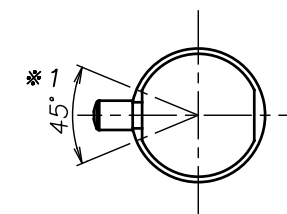
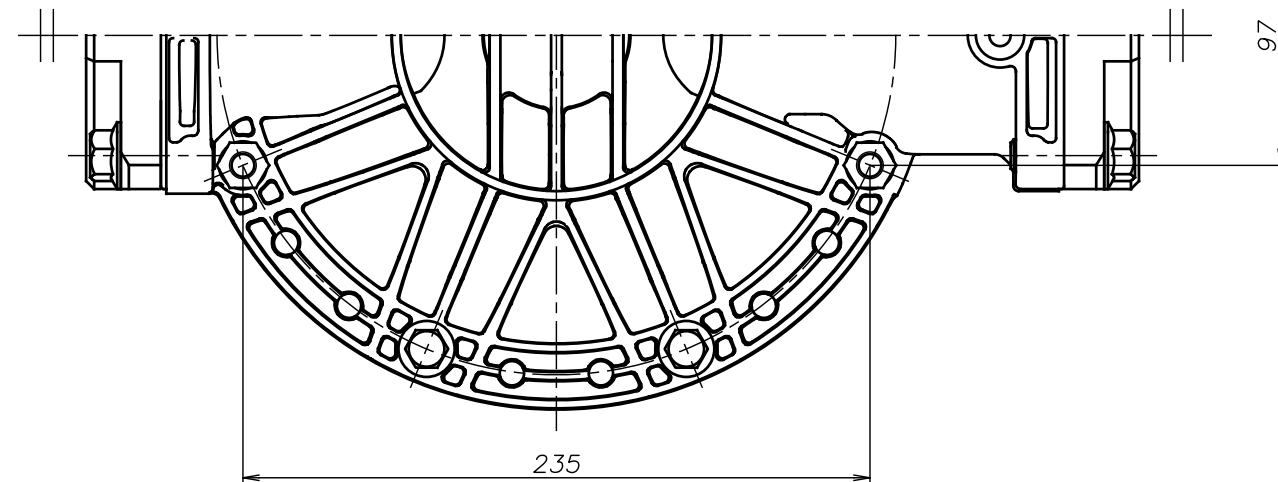
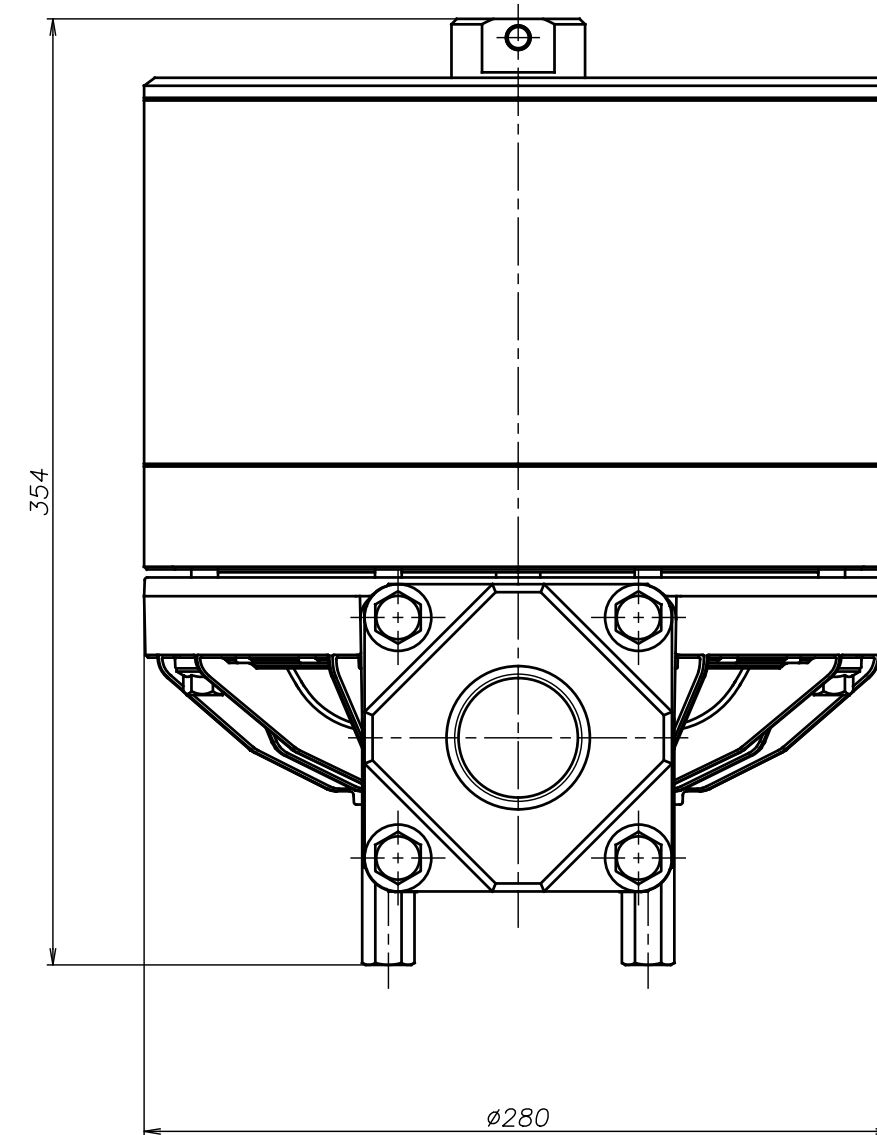
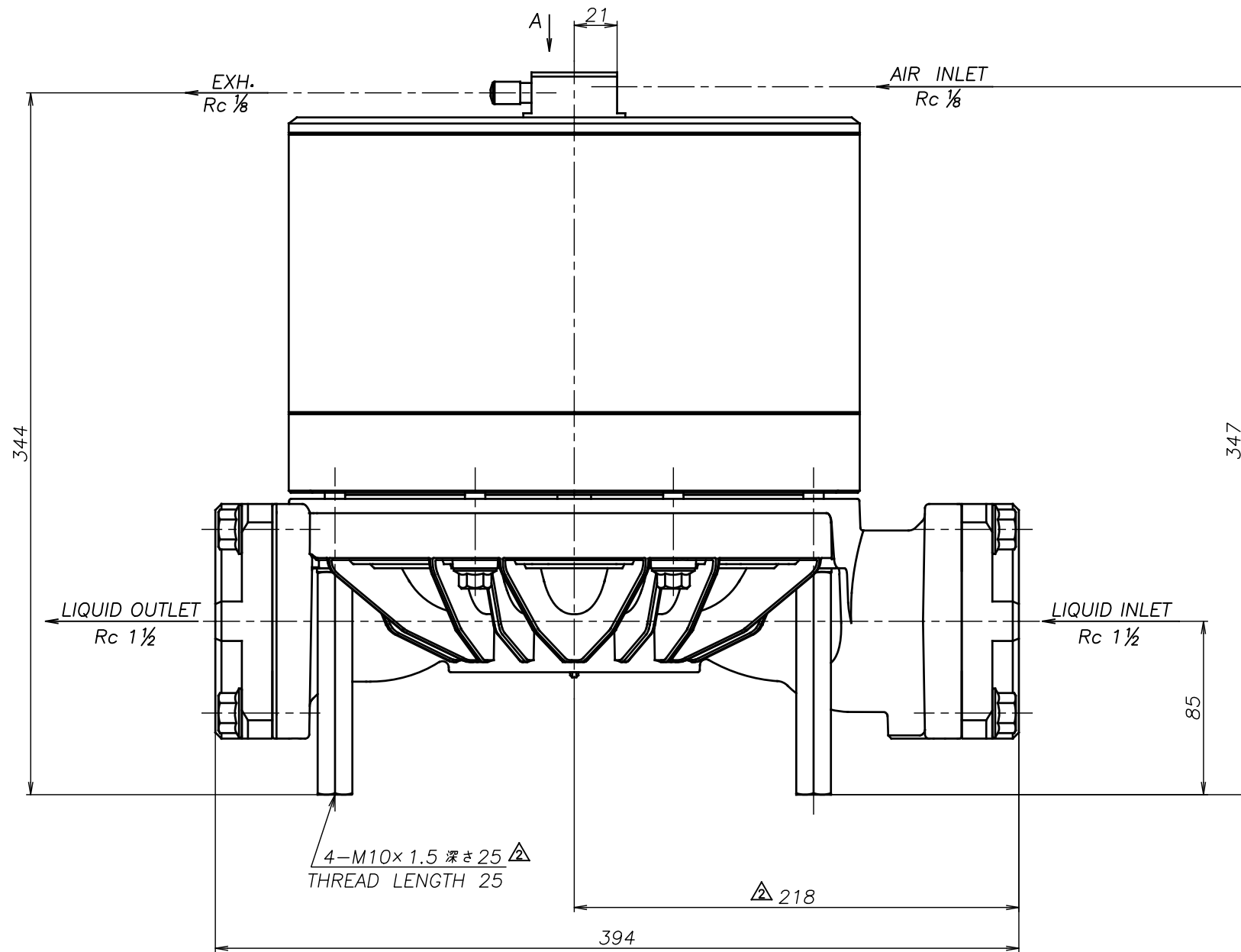

△ A部分矢視図
PARTIAL VIEW A

△ 注1) AIR INLET, EXH.は ※1 の範囲で固定されています
△ NOTE:1) AIR INLET & EXH. port are fixed in the range of ※1.

△40 AS	THIRD ANG. PROJ.	DWG.NO.
	SCALE Free	1L00343YP-E
△40 AH	THIRD ANG. PROJ.	DWG.NO.
	SCALE Free	1L00342YP-E
△40 AT	THIRD ANG. PROJ.	DWG.NO.
	SCALE Free	1L00341YP-E
△40 AV	THIRD ANG. PROJ.	DWG.NO.
	SCALE Free	1L00340YP-E
△40 AE	THIRD ANG. PROJ.	DWG.NO.
	SCALE Free	1L00339YP-E
△40 AN	THIRD ANG. PROJ.	DWG.NO.
	SCALE Free	1L00338YP-E

APP'D BY '20. 6.23 S.Murata
CHECKED BY '20. 6.23 K.Nakano
DRAWN BY '20. 6.23 K.Nakada

THE DWG. OF:
ダンパアセンブリ
DAMPER ASSEMBLY
△40 AC

YTS Co., Ltd JAPAN

THIRD ANG. PROJ. DWG.NO.
SCALE Free 1L00337YP-E