

SYM	DWG.NO	CHANGE NO	DATE	REV'D BY
△	ALL	1LE0035	'18. 9. 3	K.Nakada
△	ALL	1BE0005	'19.10.28	K.Nakada
△	ALL	1BE0006 異記訂正	'20. 6.23	K.Nakada

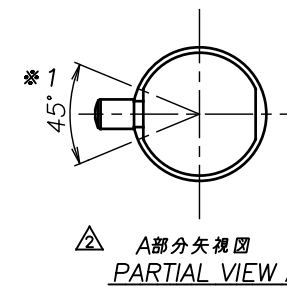
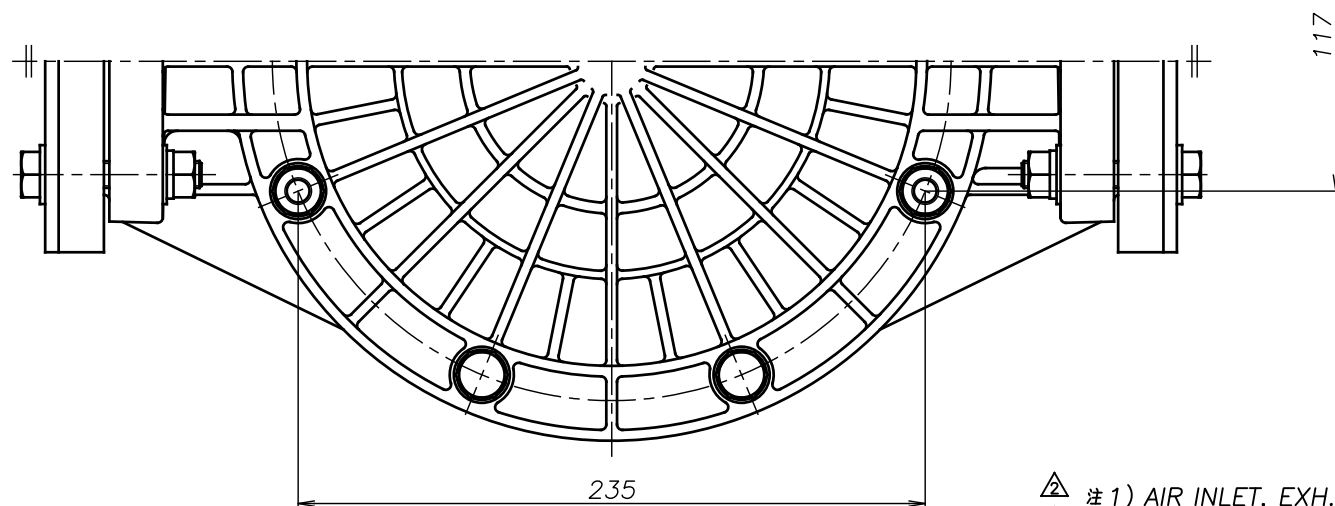
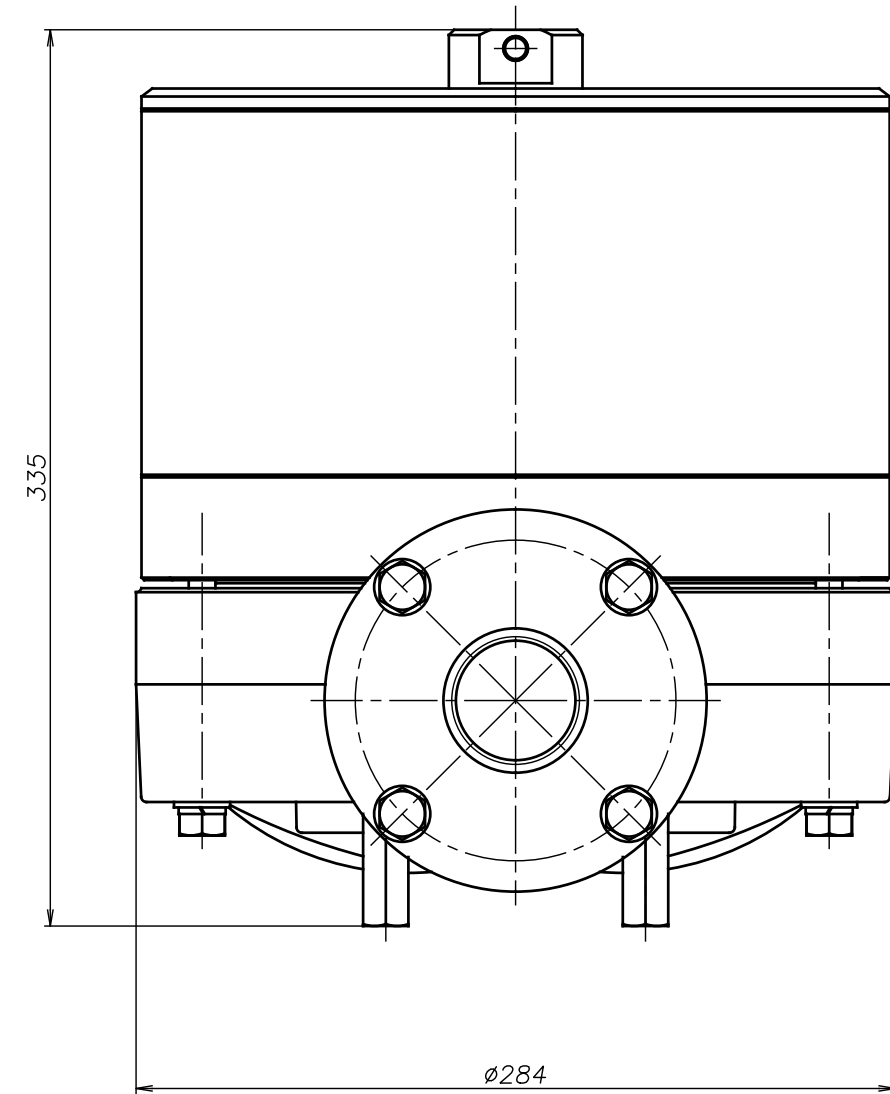
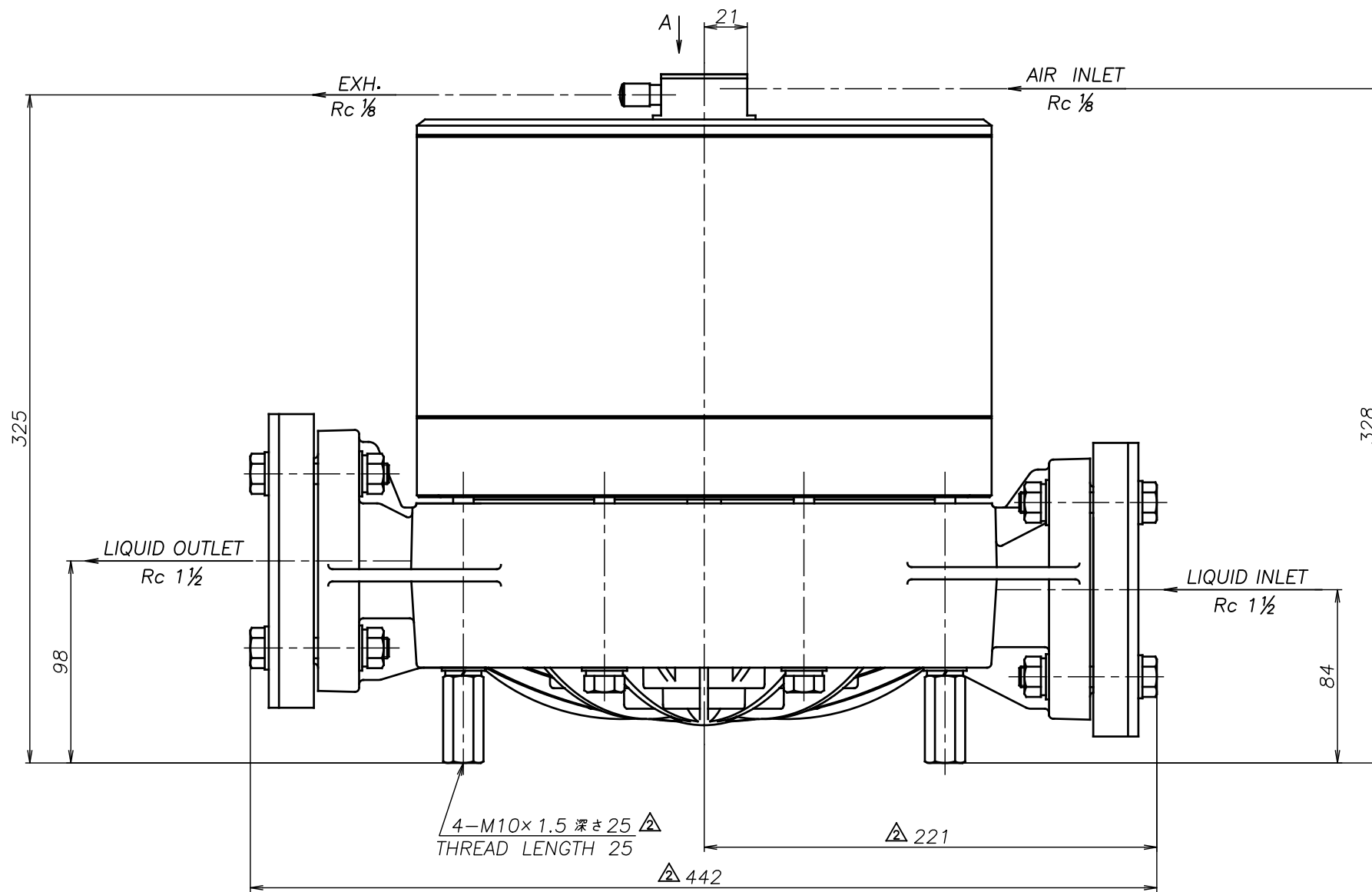

△ 注1) AIR INLET, EXH.は \*1 の範囲で固定されています  
 △ NOTE:1) AIR INLET & EXH. port are fixed in the range of \*1.

△40 GS	THIRD ANG. PROJ.	DWG.NO.
	SCALE Free	1L00357YP-E
△40 GH	THIRD ANG. PROJ.	DWG.NO.
	SCALE Free	1L00356YP-E
△40 GT	THIRD ANG. PROJ.	DWG.NO.
	SCALE Free	1L00355YP-E
△40 GV	THIRD ANG. PROJ.	DWG.NO.
	SCALE Free	1L00354YP-E
△40 GE	THIRD ANG. PROJ.	DWG.NO.
	SCALE Free	1L00353YP-E
△40 GN	THIRD ANG. PROJ.	DWG.NO.
	SCALE Free	1L00352YP-E

APP'D BY '20. 6.23 S.Murata  
 CHECKED BY '20. 6.23 K.Nakano  
 DRAWN BY '20. 6.23 K.Nakada

THE DWG. OF:  
 ダンパアセンブリ  
 DAMPER ASSEMBLY  
 △40 GC  
 THIRD ANG. PROJ. DWG.NO.  
 SCALE Free 1L00351YP-E

**YTS** Co., Ltd JAPAN