

SYM	DWG.NO	CHANGE NO	DATE	REV'D BY
△	ALL	1BE0005	'19.10.28	K.Nakada
△	ALL	1BE0006 誤記訂正	'20. 6.23	K.Nakada
△	ALL	1DE0030 表記変更	'22. 3.16	K.Nakada

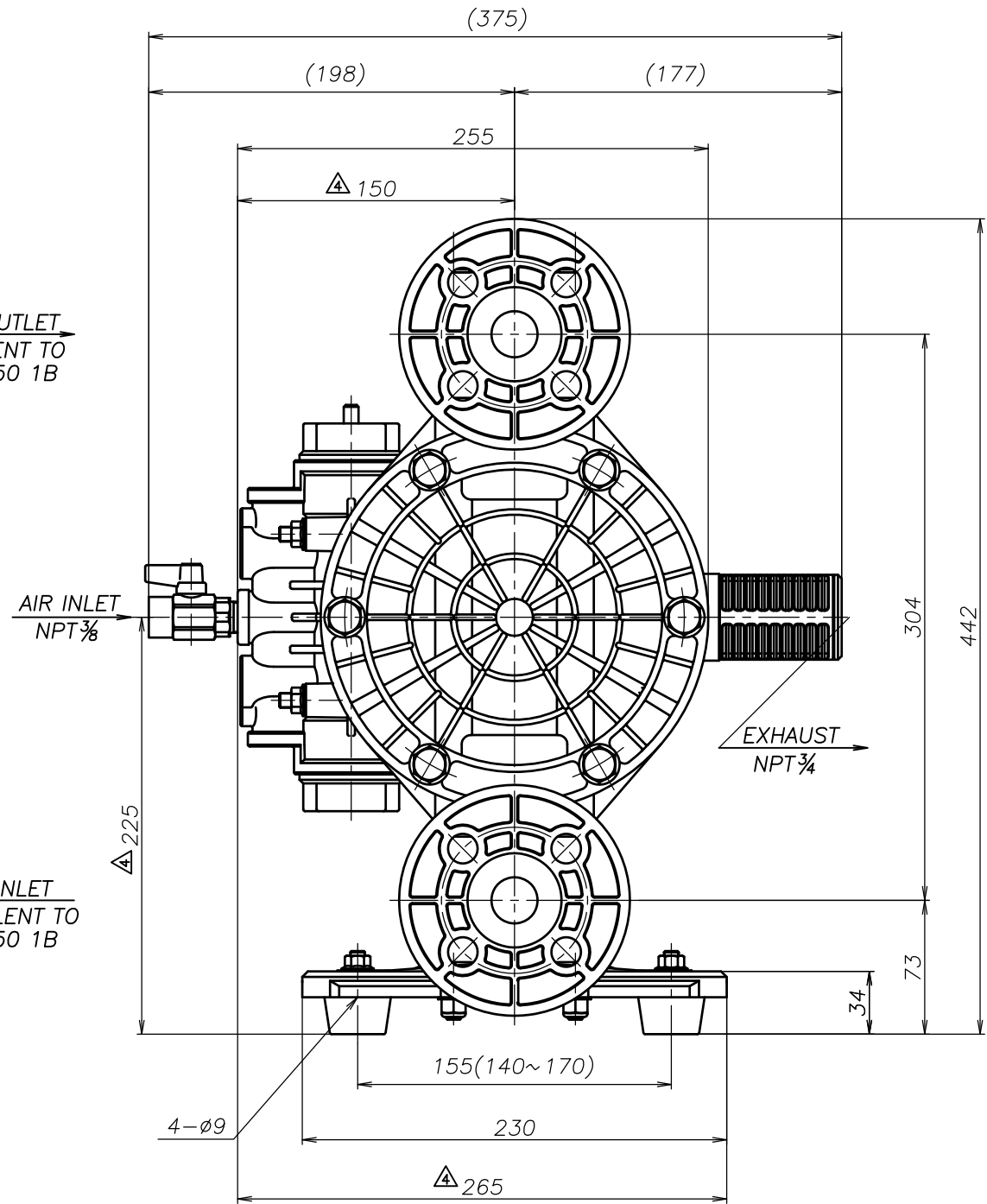
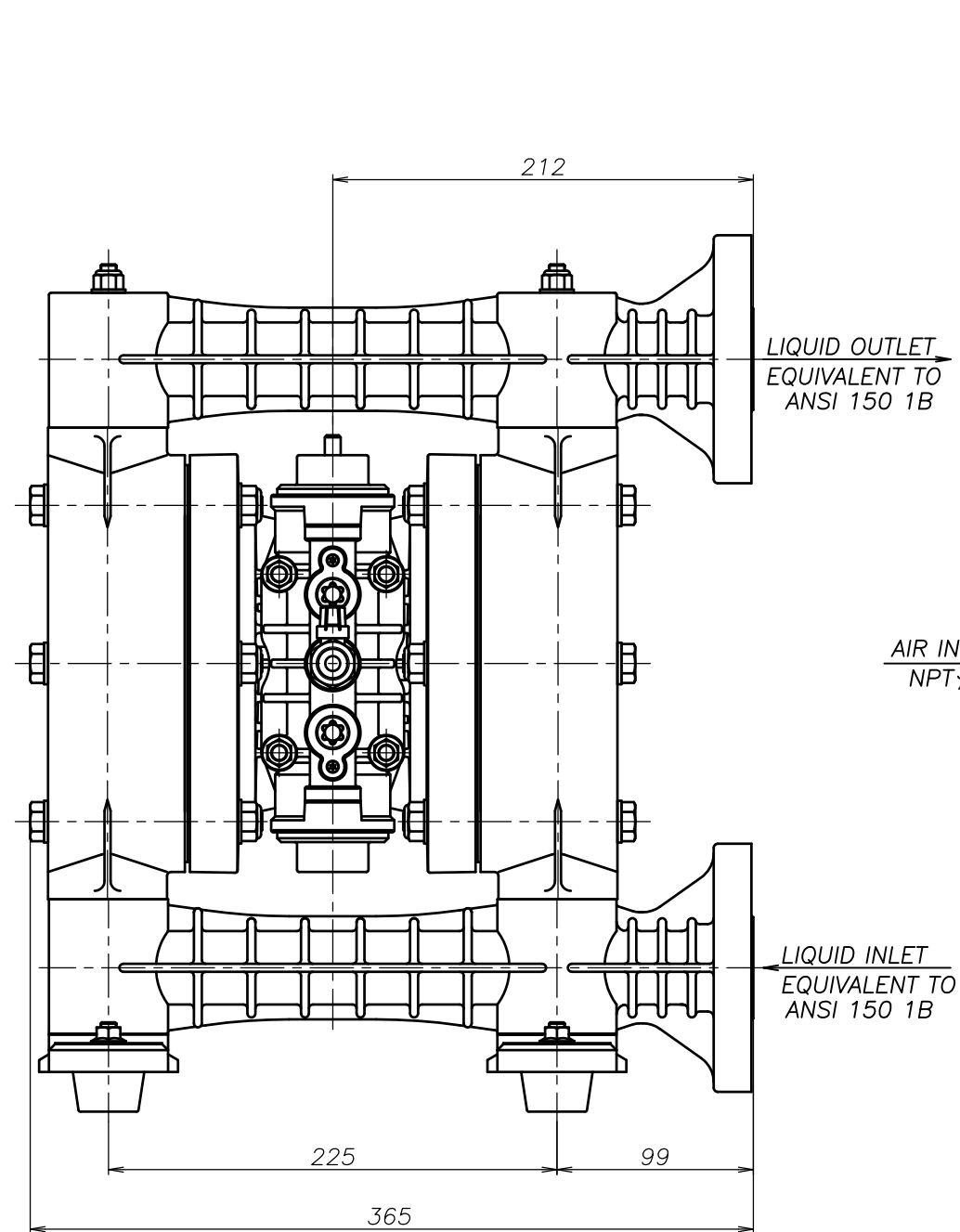

THE DWG. OF:
ダイアフラムポンプアSEMBリ
DIAPHRAGM PUMP ASSEMBLY
△250 VSA
THIRD ANG. PROJ. DWG.NO.
SCALE Free 1H00040YN-F

THE DWG. OF:
ダイアフラムポンプアSEMBリ
DIAPHRAGM PUMP ASSEMBLY
△250 VHA
THIRD ANG. PROJ. DWG.NO.
SCALE Free 1H00039YN-F

THE DWG. OF:
ダイアフラムポンプアSEMBリ
DIAPHRAGM PUMP ASSEMBLY
△250 VTA
THIRD ANG. PROJ. DWG.NO.
SCALE Free 1H00038YN-F

THE DWG. OF:
ダイアフラムポンプアSEMBリ
DIAPHRAGM PUMP ASSEMBLY
△250 VVA
THIRD ANG. PROJ. DWG.NO.
SCALE Free 1H00037YN-F

APP'D BY	'24. 3.29 S.Murata	THE DWG. OF:	ダイアフラムポンプアSEMBリ
CHECKED BY	'24. 3.29 Y.Takahashi	DIAPHRAGM PUMP ASSEMBLY	△250 VEA
DRAWN BY	'24. 3.29 J.Tomatsuri	THIRD ANG. PROJ. DWG.NO.	SCALE Free 1H00036YN-F
YTS CORPORATION JAPAN			