

SYM	DWG.NO	CHANGE NO	DATE	REV'D BY
△	ALL	1BE0005	'19.10.28	K.Nakada
△	ALL	1BE0006 誤記訂正	'20. 6.23	K.Nakada
△	ALL	1DE0030 表記変更	'22. 3.16	K.Nakada

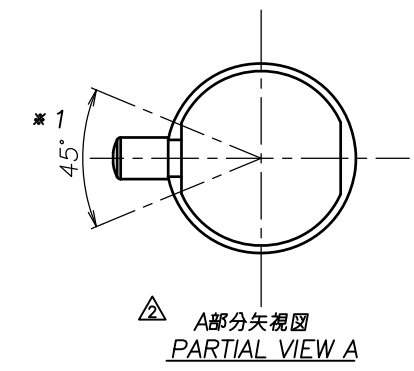
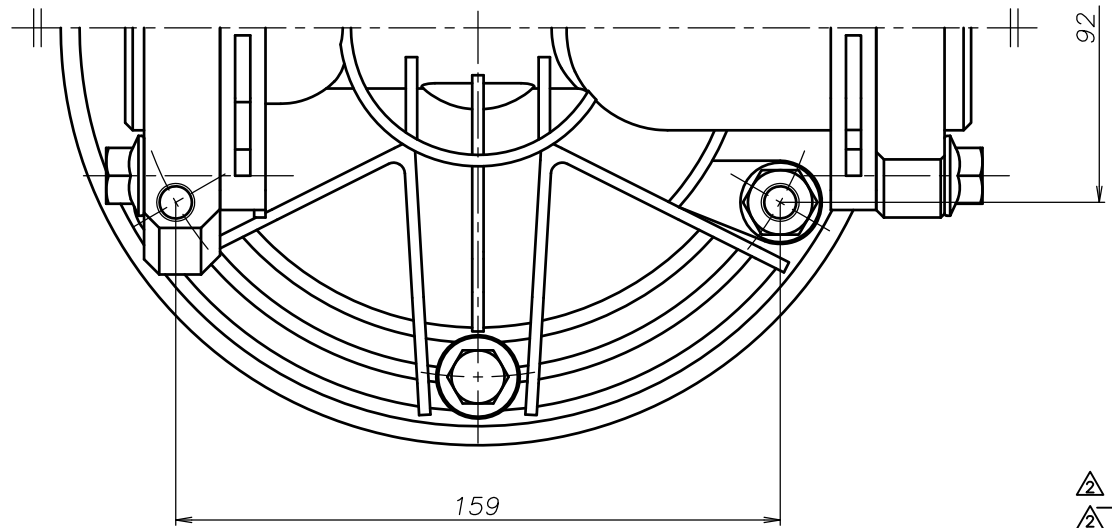
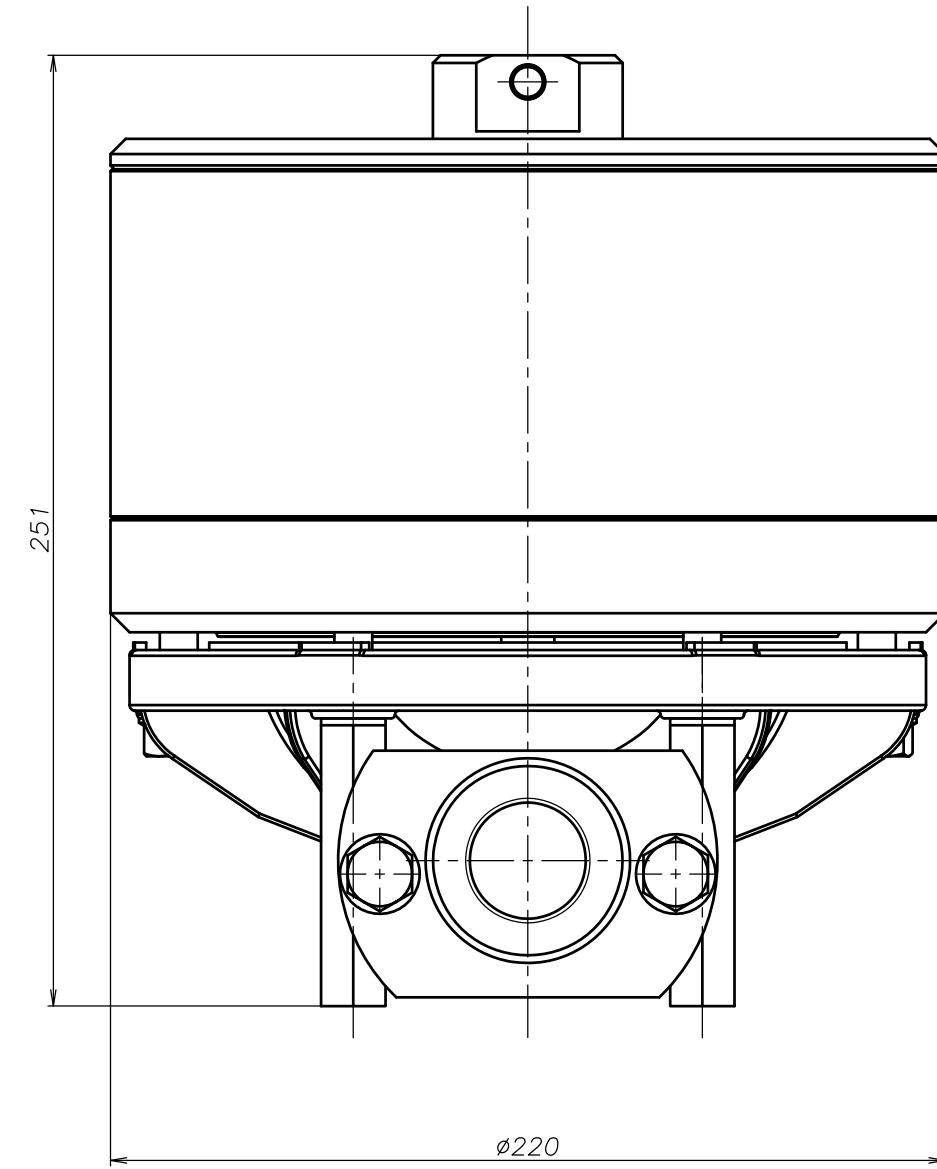
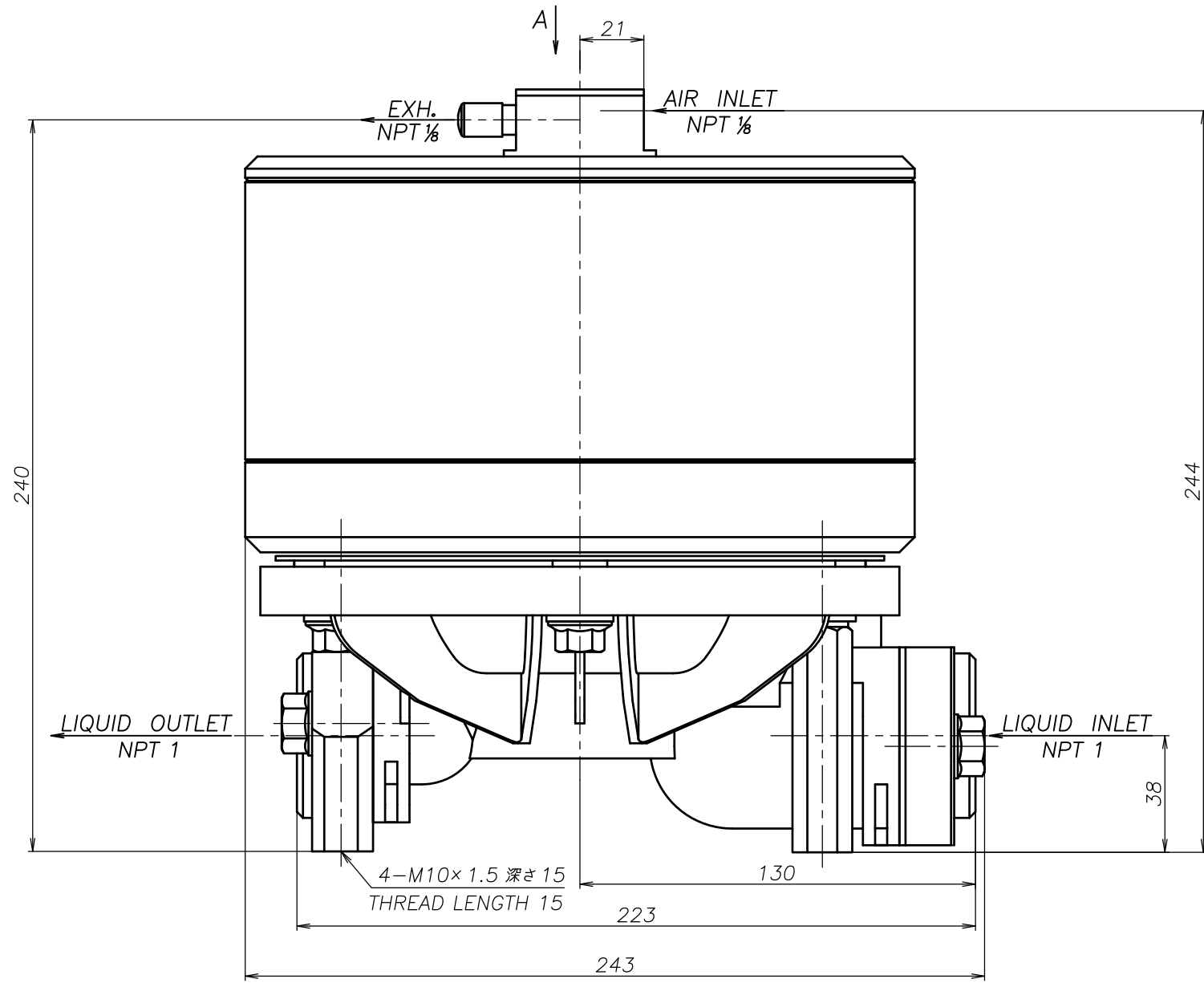

△ 注1) AIR INLET, EXH.は * 1 の範囲で固定されています
 △ NOTE:1) AIR INLET & EXH. port are fixed in the range of * 1.

THE DWG. OF:
 ダンパアセンブリ
DAMPER ASSEMBLY
 △25 ASN
 THIRD ANG. PROJ. DWG.NO.
 SCALE Free **1H00268YN-D**

THE DWG. OF:
 ダンパアセンブリ
DAMPER ASSEMBLY
 △25 AHN
 THIRD ANG. PROJ. DWG.NO.
 SCALE Free **1H00267YN-D**

THE DWG. OF:
 ダンパアセンブリ
DAMPER ASSEMBLY
 △25 ATN
 THIRD ANG. PROJ. DWG.NO.
 SCALE Free **1H00266YN-D**

THE DWG. OF:
 ダンパアセンブリ
DAMPER ASSEMBLY
 △25 AVN
 THIRD ANG. PROJ. DWG.NO.
 SCALE Free **1H00265YN-D**

THE DWG. OF:
 ダンパアセンブリ
DAMPER ASSEMBLY
 △25 AEN
 THIRD ANG. PROJ. DWG.NO.
 SCALE Free **1H00264YN-D**

THE DWG. OF:
 ダンパアセンブリ
DAMPER ASSEMBLY
 △25 ANN
 THIRD ANG. PROJ. DWG.NO.
 SCALE Free **1H00263YN-D**

APP'D BY '24. 3.29 S.Murata THE DWG. OF:
 ダンパアセンブリ
DAMPER ASSEMBLY
 △25 ACN
 CHECKED BY '24. 3.29 Y.Takahashi
 DRAWN BY '24. 3.29 J.Tomatsuri
 THIRD ANG. PROJ. DWG.NO.
 SCALE Free **1H00262YN-D**
YTS Co., Ltd JAPAN