

SYM	DWG.NO	CHANGE NO	DATE	REV'D BY
1L00031YN-A	1LE0007		'16. 6.16	S.Murata
△ 1L00031YN-B	1BE0005		'19.10.28	K.Nakada
△ 1L00031YN-C	1BE0006	誤記訂正	'20. 6.23	K.Nakada

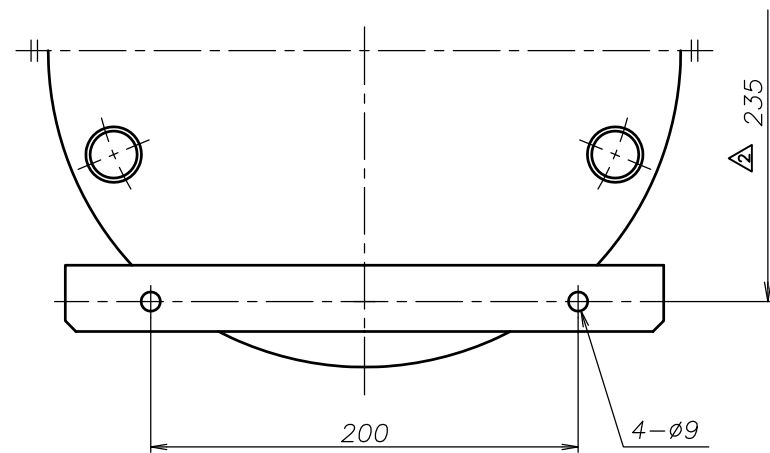
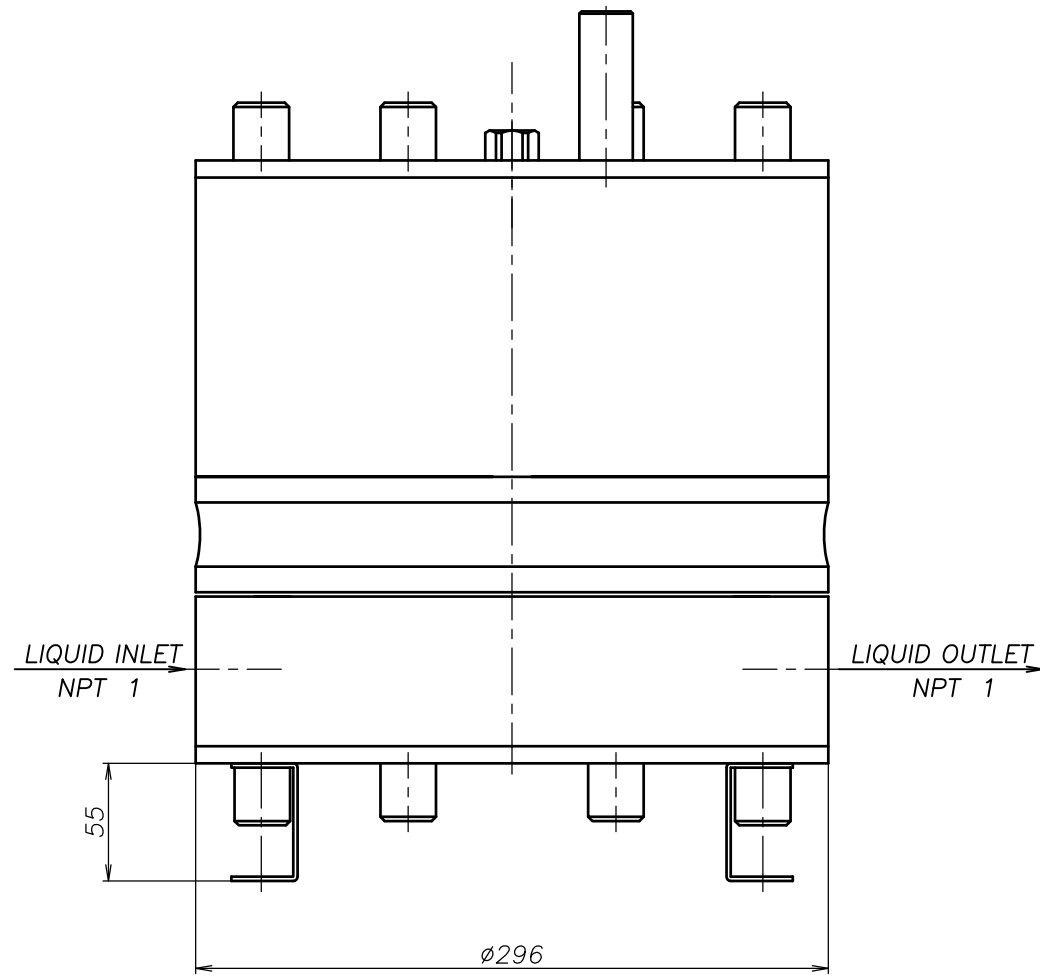
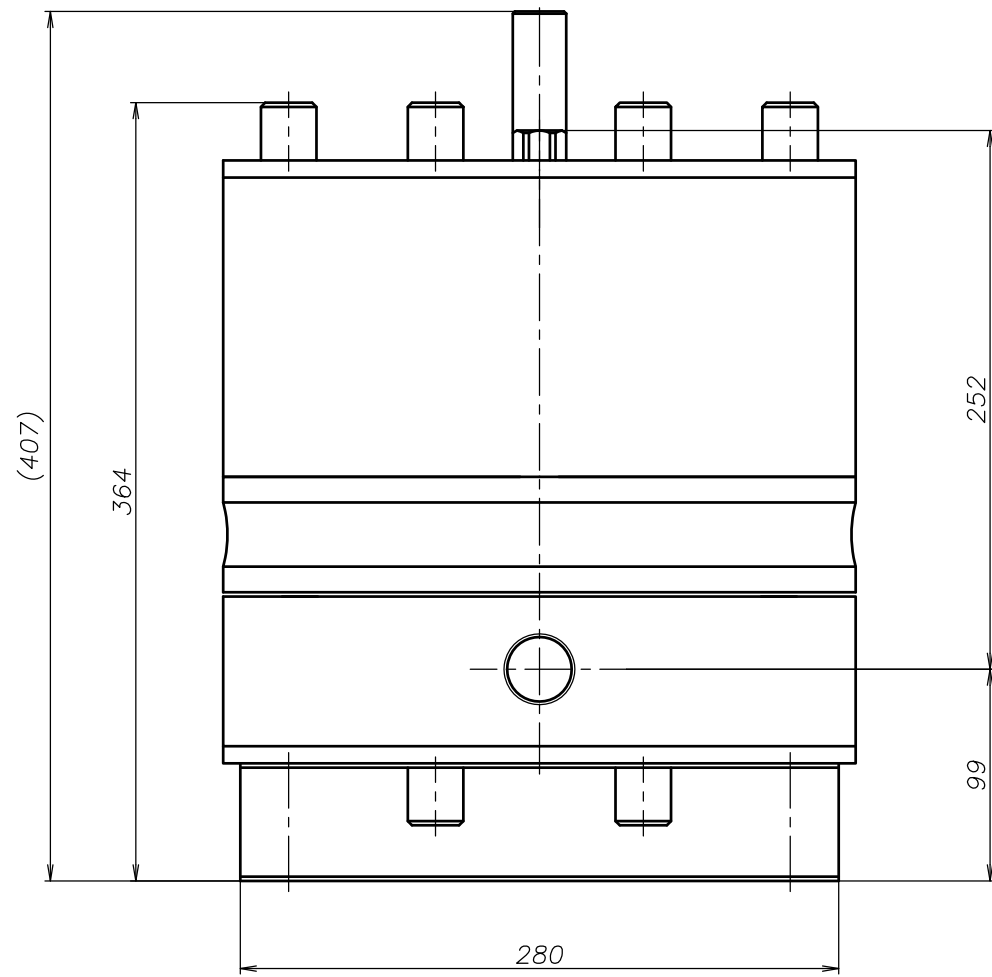
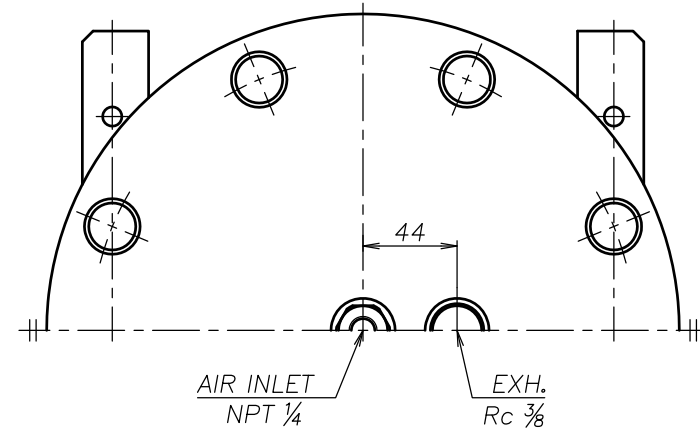

APP'D BY	'24. 3.29 S.Murata	THE DWG. OF:	ダンパアSEMBリー
CHECKED BY	'24. 3.29 Y.Takahashi	DAMPER ASSEMBLY	
DRAWN BY	'24. 3.29 J.Tomatsuri	△40 HTN	
YTS Co., Ltd JAPAN		THIRD ANG. PROJ.	DWG.NO.
		SCALE Free	1L00031YN-C