

SYM	DWG.NO	CHANGE NO	DATE	REV'D BY
△	ALL	1BE0005	'19.10.28	K.Nakada
△	ALL	1BE0006 誤記訂正	'20.6.23	K.Nakada
△	ALL	1DE0030 表記変更	'22.3.16	K.Nakada

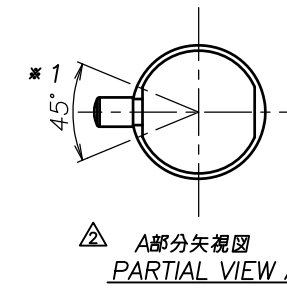
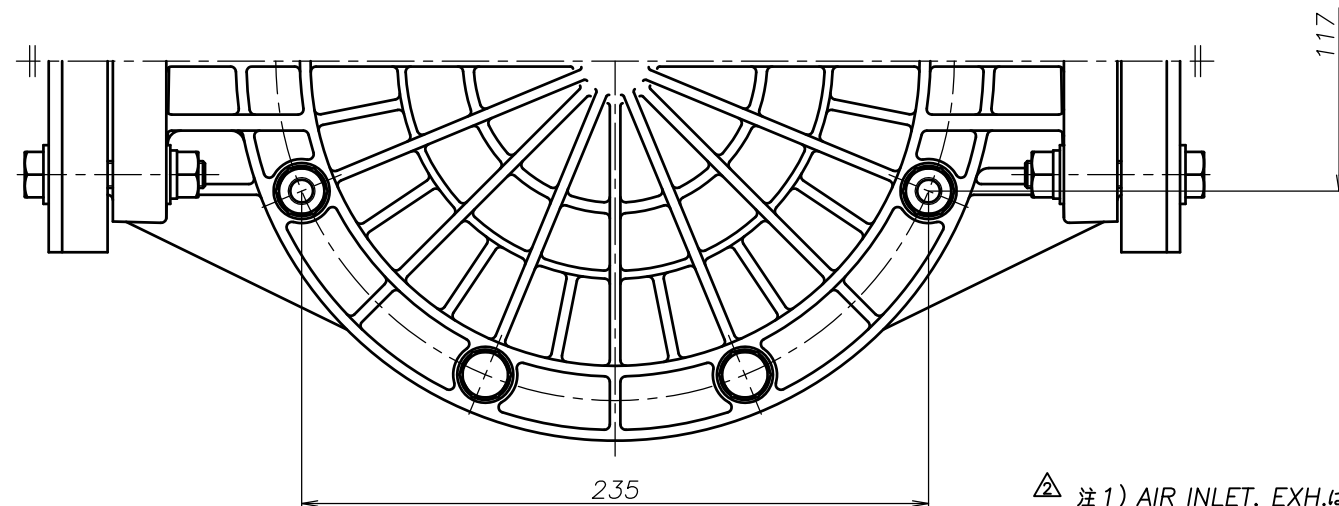
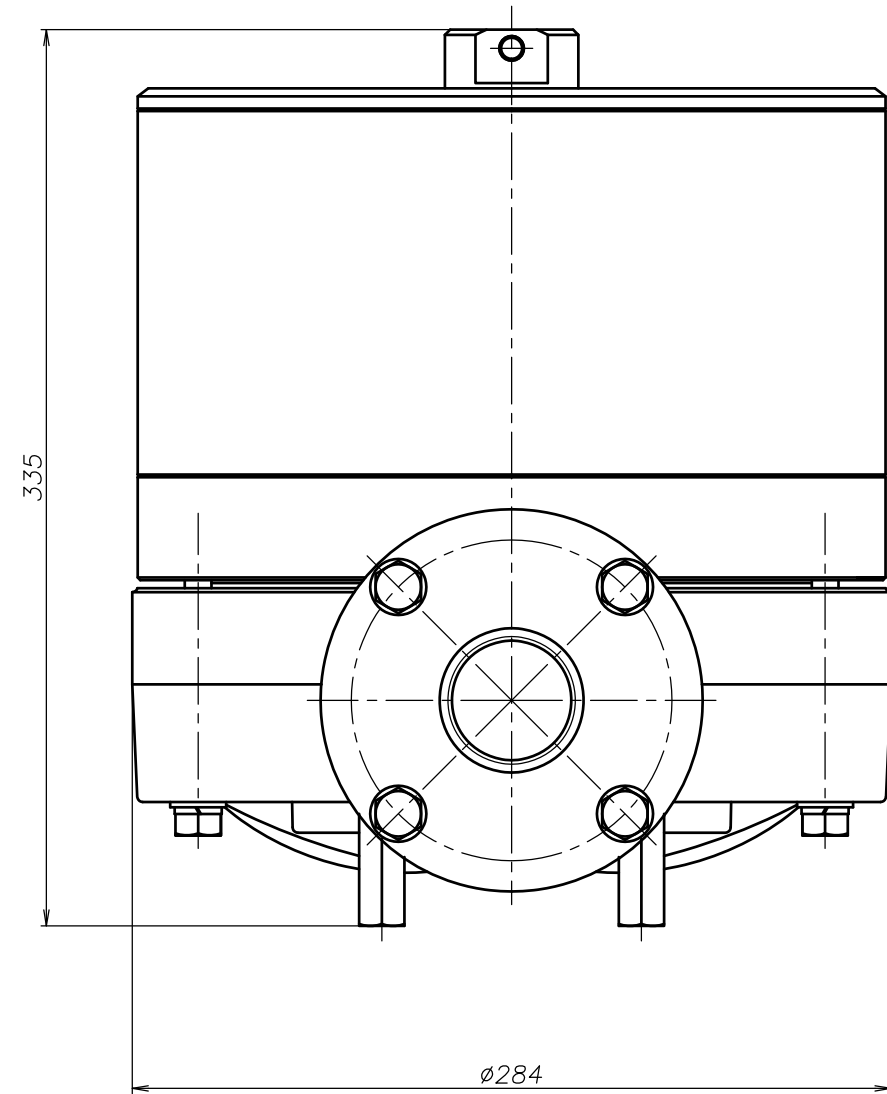
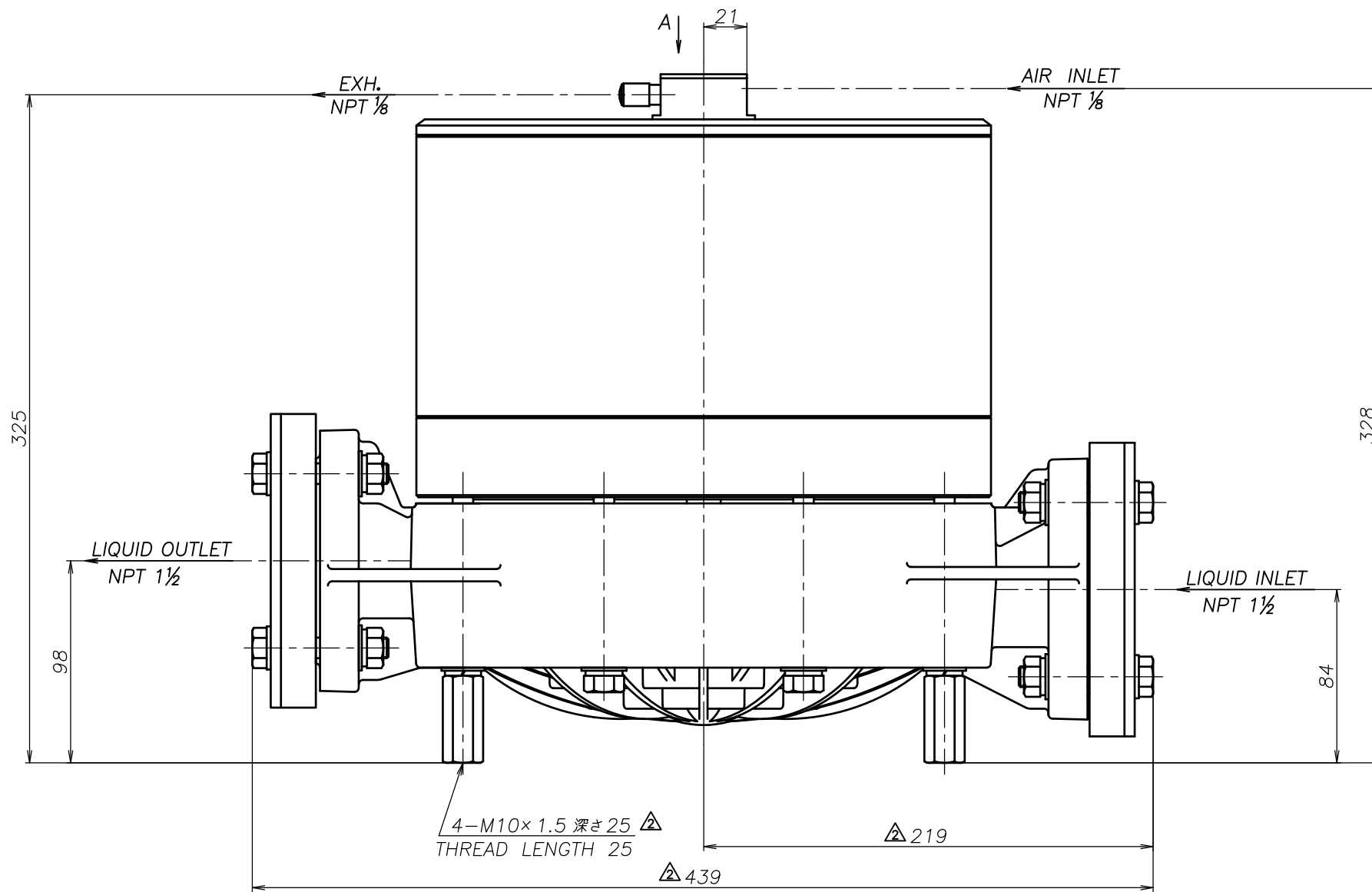

△ 注1) AIR INLET, EXH.は *1 の範囲で固定されています
 △ NOTE:1) AIR INLET & EXH. port are fixed in the range of *1.

THE DWG. OF: ダンパアセンブリ DAMPER ASSEMBLY	
△40 VSN	
THIRD ANG. PROJ.	DWG.NO.
SCALE Free	1L00362YN-F

APP'D BY '24.3.29 S.Murata	THE DWG. OF: ダンパアセンブリ DAMPER ASSEMBLY
CHECKED BY '24.3.29 Y.Takahashi	△40 VTN
DRAWN BY '24.3.29 J.Tomatsuri	THIRD ANG. PROJ.
YTS Co., Ltd JAPAN	DWG.NO.
	SCALE Free
	1L00360YN-F