

SYM	DWG.NO	CHANGE NO	DATE	REV'D BY
△	ALL	1BE0005	'19.10.28	K.Nakada
△	ALL	1BE0006 誤記訂正	'20. 6.23	K.Nakada
△	ALL	1DE0030 表記変更	'22. 3.16	K.Nakada

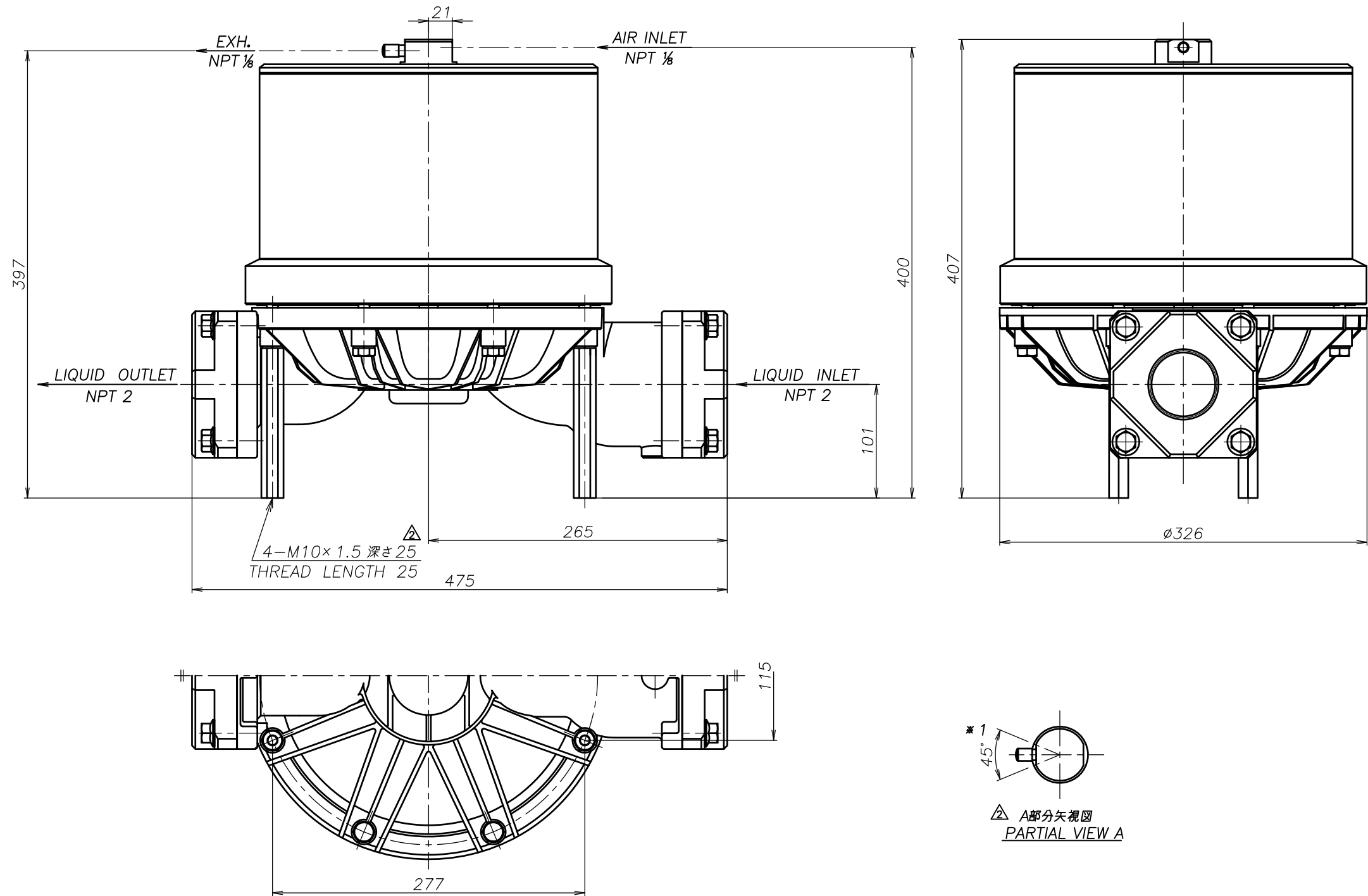

THE DWG. OF: ダンパアセンブリ DAMPER ASSEMBLY △50 SSN	THIRD ANG. PROJ. DWG.NO. SCALE Free 1M00150YN-D
THE DWG. OF: ダンパアセンブリ DAMPER ASSEMBLY △50 SHN	THIRD ANG. PROJ. DWG.NO. SCALE Free 1M00149YN-D
THE DWG. OF: ダンパアセンブリ DAMPER ASSEMBLY △50 STN	THIRD ANG. PROJ. DWG.NO. SCALE Free 1M00148YN-D
THE DWG. OF: ダンパアセンブリ DAMPER ASSEMBLY △50 SVN	THIRD ANG. PROJ. DWG.NO. SCALE Free 1M00147YN-D
THE DWG. OF: ダンパアセンブリ DAMPER ASSEMBLY △50 SEN	THIRD ANG. PROJ. DWG.NO. SCALE Free 1M00146YN-D
THE DWG. OF: ダンパアセンブリ DAMPER ASSEMBLY △50 SNN	THIRD ANG. PROJ. DWG.NO. SCALE Free 1M00145YN-D

△ 注1) AIR INLET, EXH.は $\ast 1$ の範囲で固定されています
 △ NOTE:1) AIR INLET & EXH. port are fixed in the range of $\ast 1$.

APP'D BY '23. 4.10 S.Murata	THE DWG. OF: ダンパアセンブリ DAMPER ASSEMBLY △50 SCN
CHECKED BY '23. 4.10 K.Nakano	THIRD ANG. PROJ. DWG.NO. SCALE Free 1M00144YN-D
DRAWN BY '23. 4.10 K.Nakada	
YTS Co., Ltd JAPAN	