

SYM	DWG.NO	CHANGE NO	DATE	REV'D BY
△	ALL	1BE0006 誤記訂正	'20. 6.23	K.Nakada
△	ALL	1DE0030 表記変更	'22. 3.16	K.Nakada
△	ALL	1ME0053 構成変更	'22. 8.29	Y.Takahashi

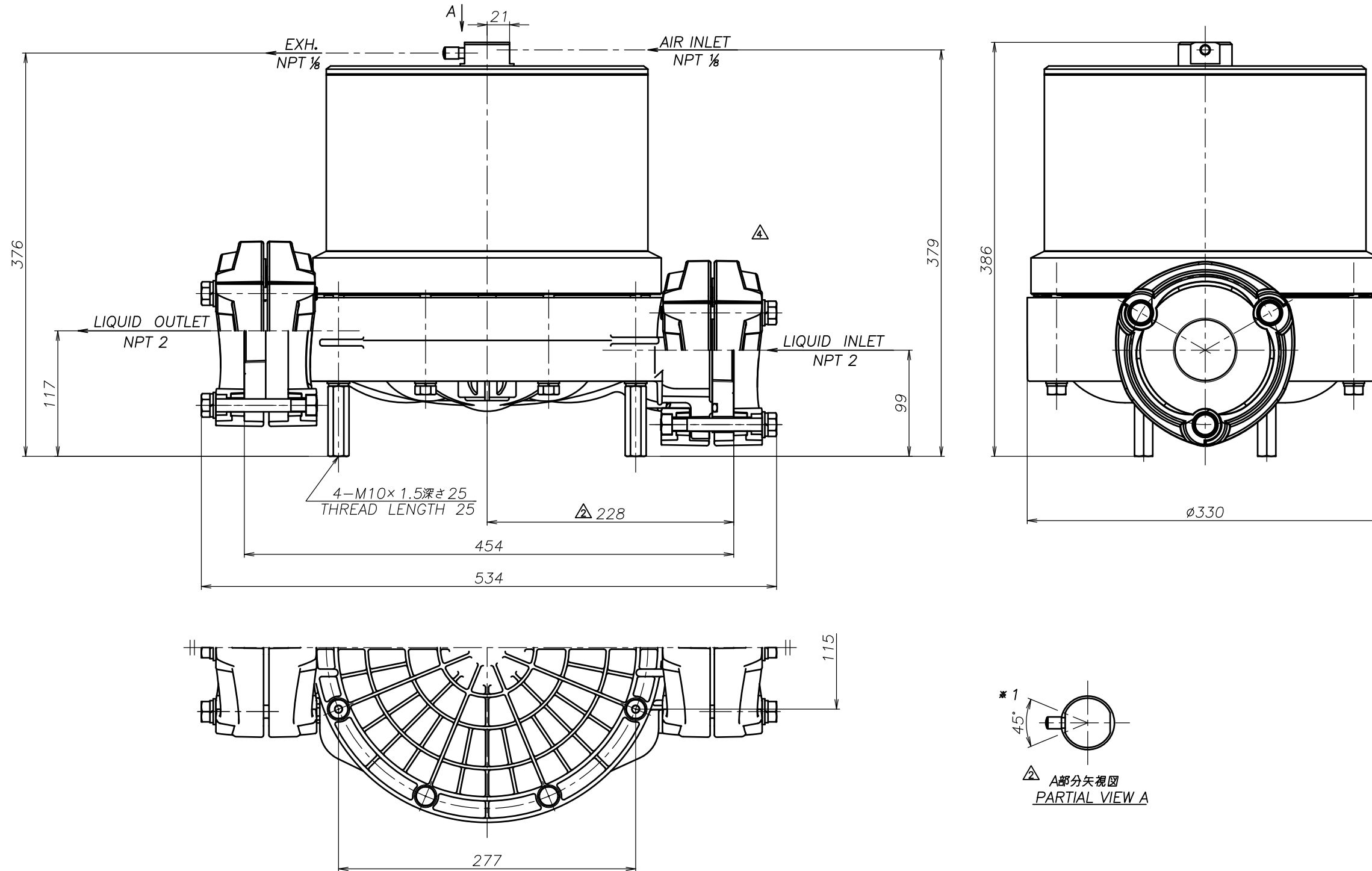

△ 注1) AIR INLET, EXH.は * 1 の範囲で固定されています
 △ NOTE:1) AIR INLET & EXH. port are fixed in the range of * 1.

THE DWG. OF:	
ダンパアセンブリ DAMPER ASSEMBLY	
50 VSN	
THIRD ANG. PROJ.	DWG.NO.
SCALE Free	1M00169YN-E

APP'D BY	'24. 3.29 S.Murata	THE DWG. OF:
CHECKED BY	'24. 3.29 Y.Takahashi	ダンパアセンブリ DAMPER ASSEMBLY
DRAWN BY	'24. 3.29 J.Tomatsuri	50 VTN
YTS Co., Ltd JAPAN		THIRD ANG. PROJ.
		SCALE Free
		DWG.NO.
		1M00167YN-E