

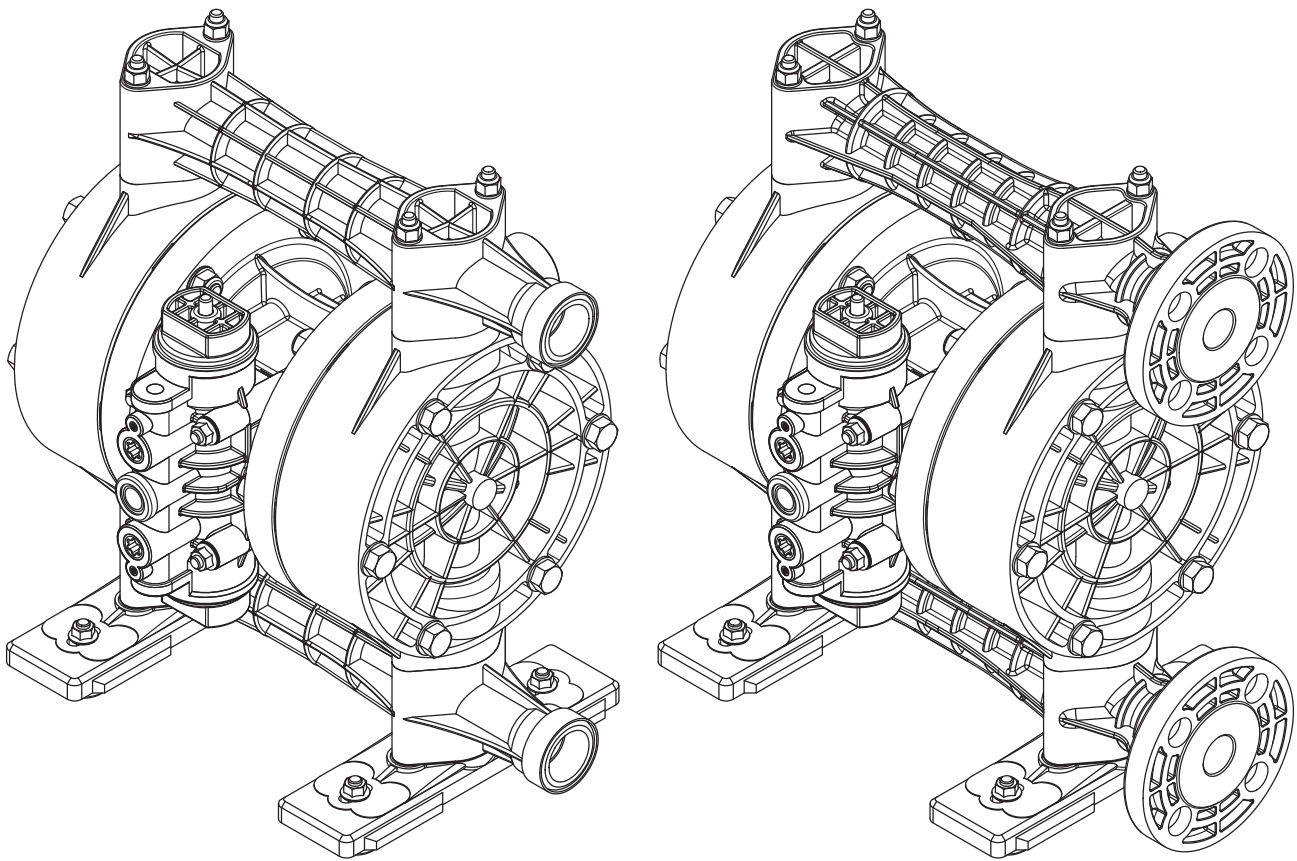

PUMP SERVICE BOOK



TC-X200G TC-X200V
TC-X250G TC-X250V TC-X250C
Series Pumps

HOW TO USE THE PUMP SERVICE BOOK

TC-X200GV TC-X250GV Series Pumps

- The servicing method for each pump can be different depending on the model and size. Please refer to the "Model Name" noted on the Pump Identification Plate and use the below table as a page number and diagram reference guide.

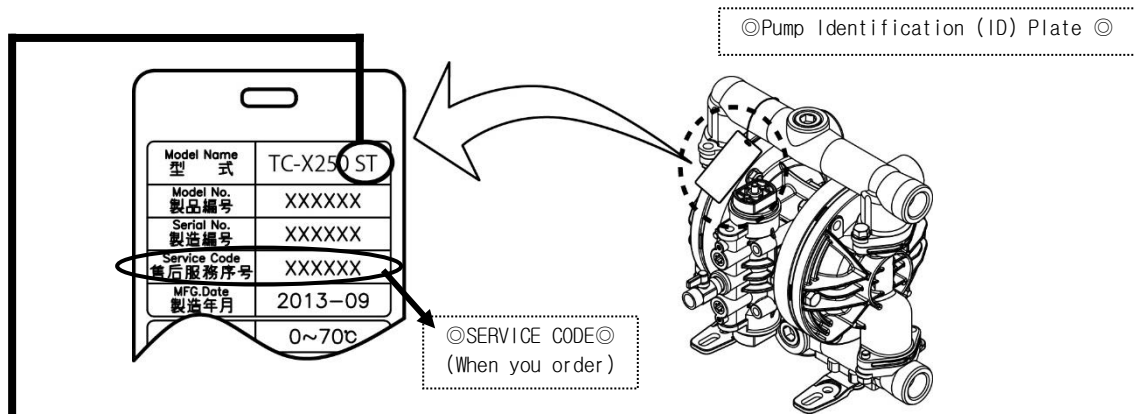

| | · BALL · VALVE SEAT · FLAT VALVE | · DIAPHRAGM · CENTRE DISK | · CENTRE DISK · DIAPHRAGM · Mounting Direction | · THROAT BEARING · PILOT VALVE | · C SPOOL ASSEMBLY · SPOOL ASSEMBLY | · Exploded View ※ 1 · Assembly torque values / Re-torque values |
|---|---|------------------------------|--|-----------------------------------|--|--|
| Pump Model Code | Page Number & Diagram Reference Numbers | | | | | |
| GC GN GE GV VE VV CC CN CE CV | 1-①(200) 1-②(250) | 2 | 3-① | 4 | 5 | 6-①(200) 6-②(250) |
| GH GS VH VS CH CS | 1-①(200) 1-②(250) | 2 | 3-② | 4 | 5 | 6-①(200) 6-②(250) |
| GT VT CT | 1-①(200) 1-②(250) | 2 | 3-③ | 4 | 5 | 6-①(200) 6-②(250) |

※ 1) Before operating the pump for the first time please re-torque all bolts. Also re-torque bolts if leaks are discovered as part of the daily inspection regime.

Description of Diagrams used within the Pump Service Book

| | | | | | | | |
|--|--|--|--|--|----------------------------------|--|---------------------------------|
| | Check Condition & Measurements Carefully | | Use Oil to help with Assembly | | Use Grease to help with Assembly | | Apply LOCTITE® to adhere |
| | If within tolerance then continue to Use | | If beyond allowable tolerance then dispose | | Replace with New Parts | | Hand-tight |

⚠ WARNING



For your own safety and the safety of the people around you, be sure to read the procedures noted within carefully before performing maintenance on this product. After reading this document, be sure to keep it handy for future reference.

⚠ WARNING



Before commencing any maintenance work, Disconnect the compressed air supply and remove and clean any remaining liquids contained on around or within the pump. If liquids are not removed or neutralized then there is a possibility of a serious injury such as burns, blindness, poisoning or even death if chemicals adhere to the skin eyes or are accidentally inhaled or swallowed. If residual air pressure is present within the pump there could be a danger of sudden decompression or explosion resulting in severe injury or even death. In case of disassembling, be sure to wear protective equipment, such as face mask, gloves, etc. When replacing spare parts, be sure to use genuine YTS parts. The installation and use of non-specified parts may cause a malfunction or damage to the product.

Service Tools

Ⓐ Sleeve Puller Tool And PP Wrench (Can be purchased separately)

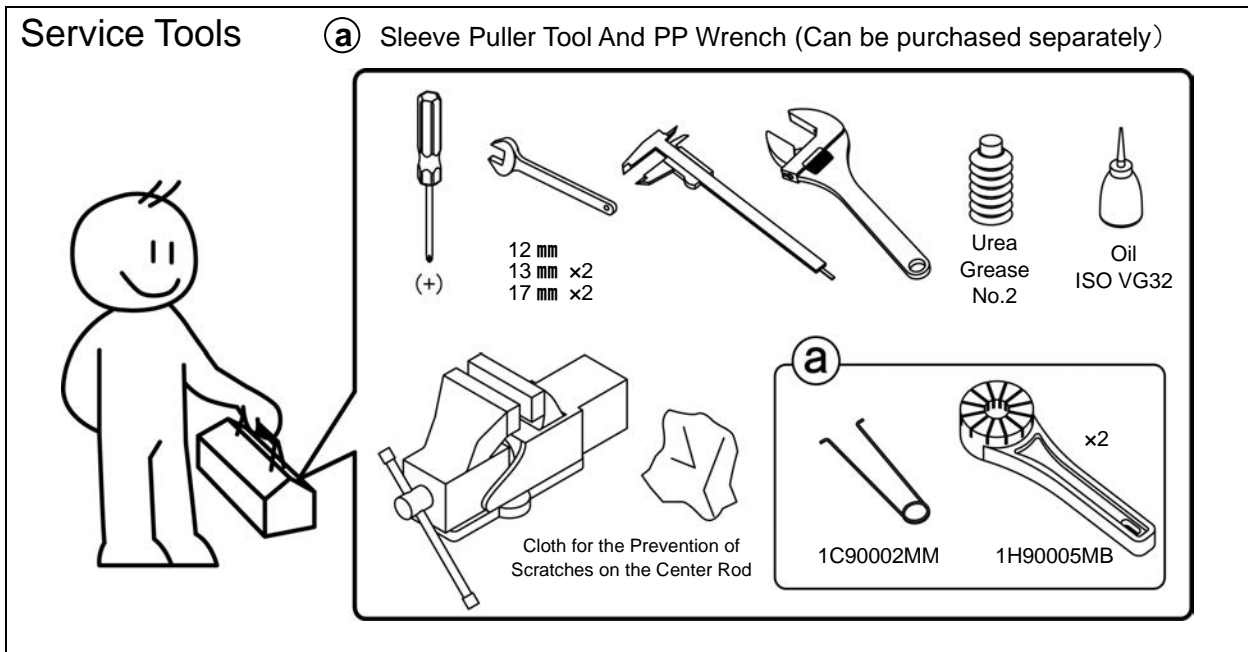

Recommended Changeover Time for the Replacement of Diaphragms ※

| | |
|---------------|--------------------|
| CR, NBR, EPDM | 10 million cycles |
| FKM | 2.5 million cycles |
| PTFE | 3 million cycles |
| TPEE, TPO | 15 million cycles |

- ※ Conditions; with fresh water at room temperature and 0 head
Conditions such as over pressurization, dry running high or low temperatures, Chemical attack or Abrasion etc. can drastically shorten diaphragm life.
- ※ O-rings and packing should be replaced during service.
- ※ When reassembling the pump please follow the disassembly Procedure in reverse. For all torque values refer to the Exploded view on page 6.
- ※ When ordering spare parts, please refer to the pump "SERVICE CODE". As stated on the Identification plate.

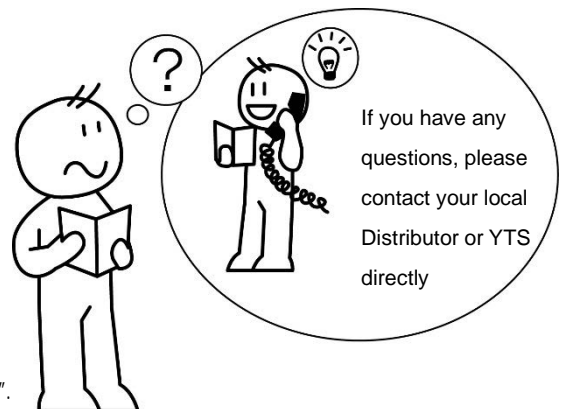

Retightening

1. Before starting operation.
2. At quarterly inspections after installation. (Biannual if the room temperature, such as in a clean room, is maintained within plus or minus 5°C of the ambient temperature.)
3. When restarting the pump with low temperature after it stops running because ambient temperature or liquid temperature becomes too high, and low while it stops.
4. If you find fluid leakage on daily inspection.

1-① (200)GC GN GE GV GH GS GT VE VV VT VH VS

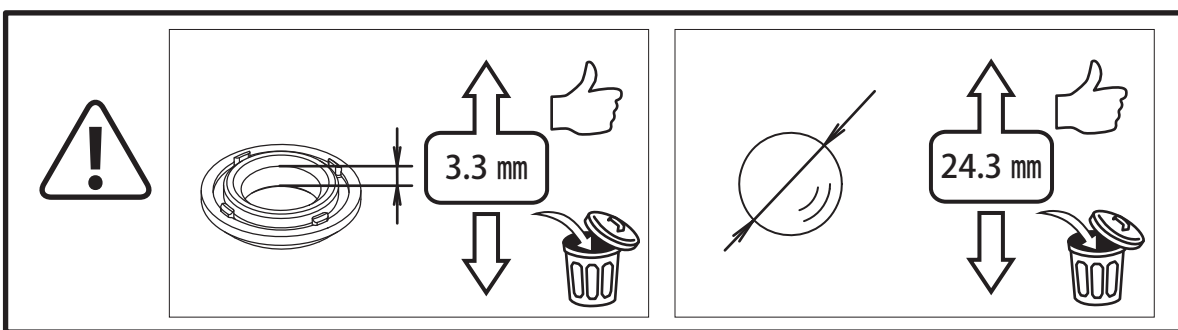
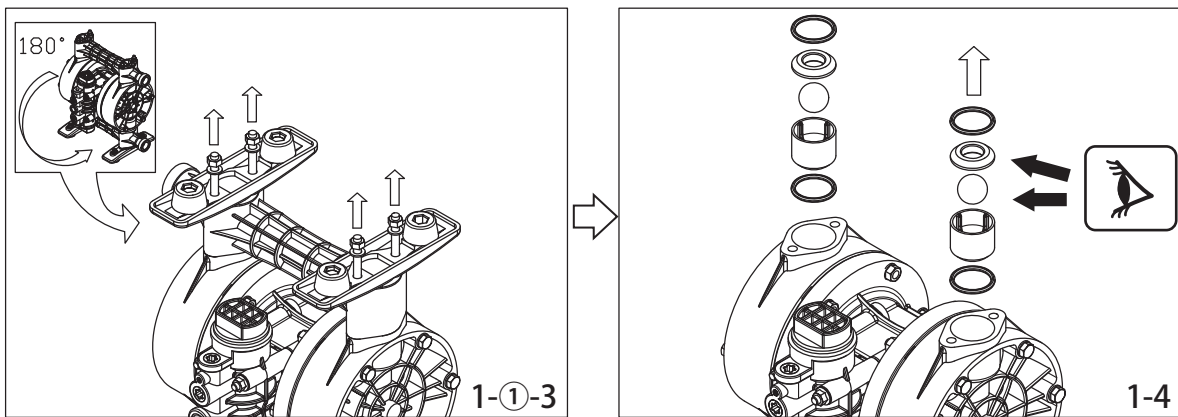
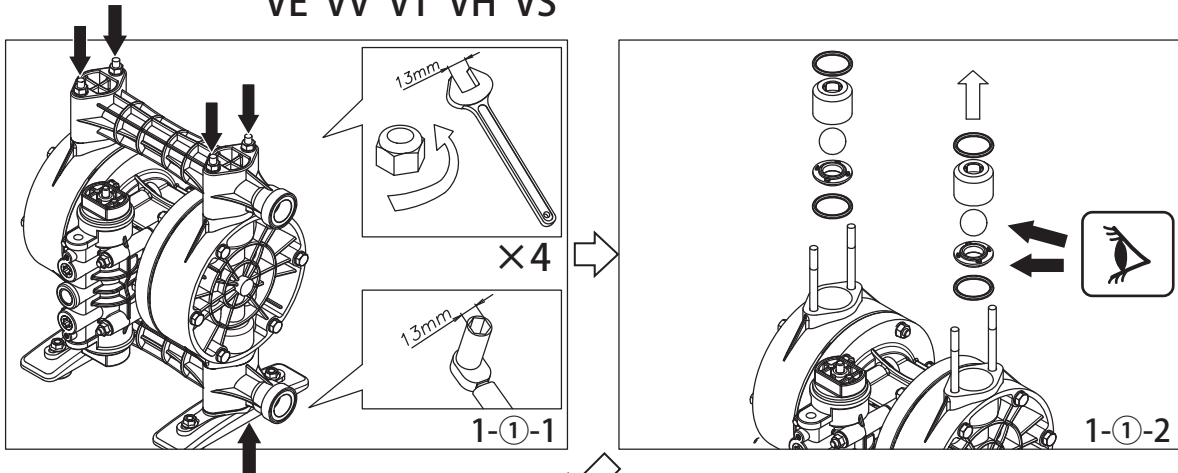

1

1-② (250) GC GN GE GV GH GS GT
VE VV VT VH VS
CC CN CE CV CT CH CS

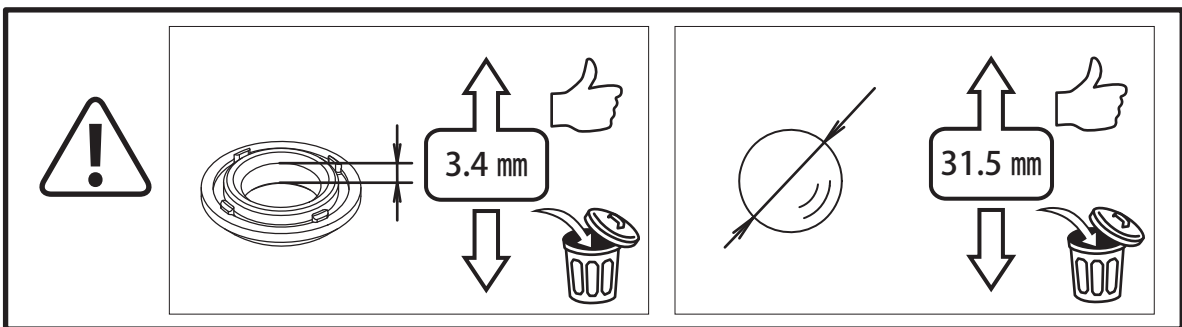
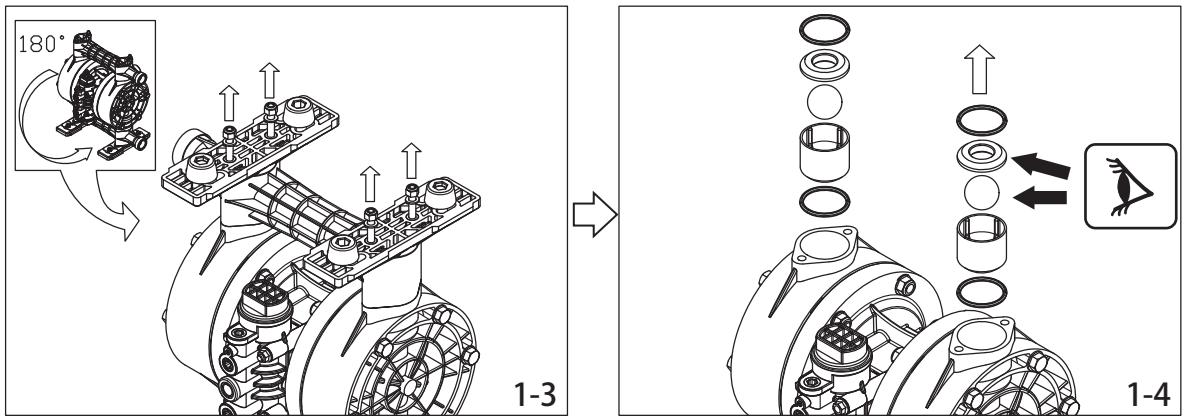
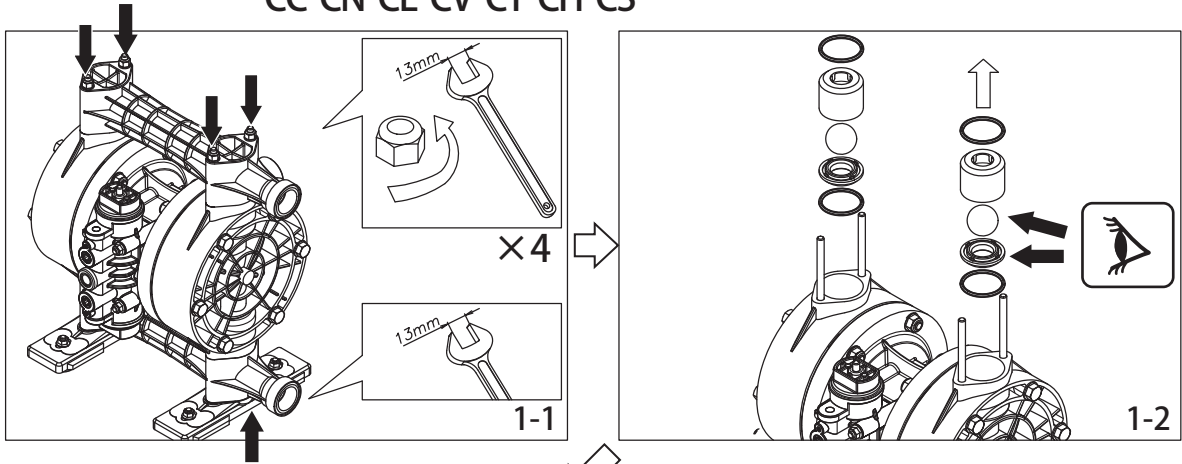

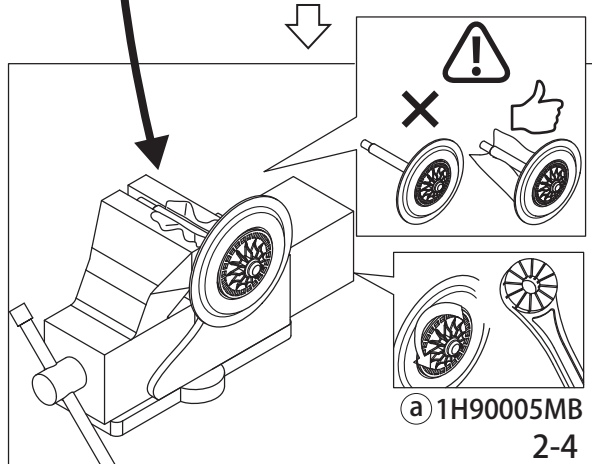
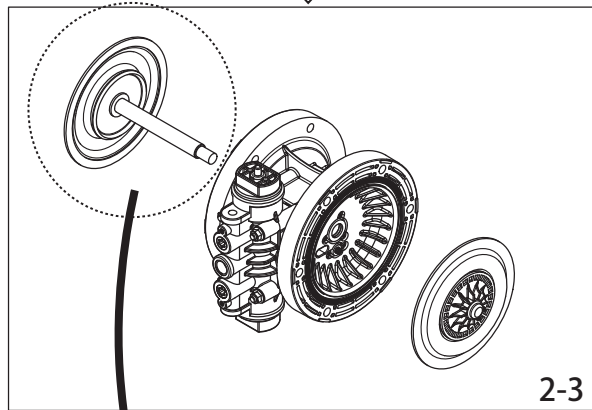
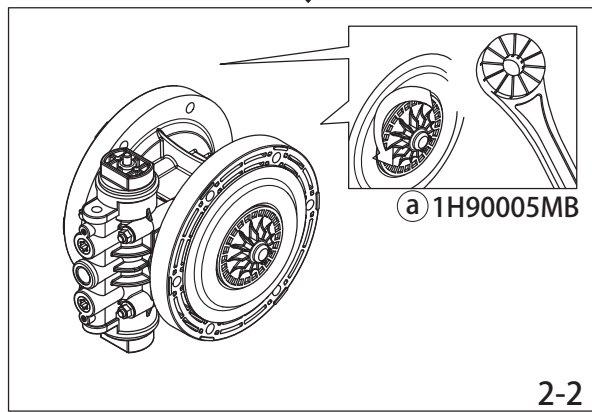
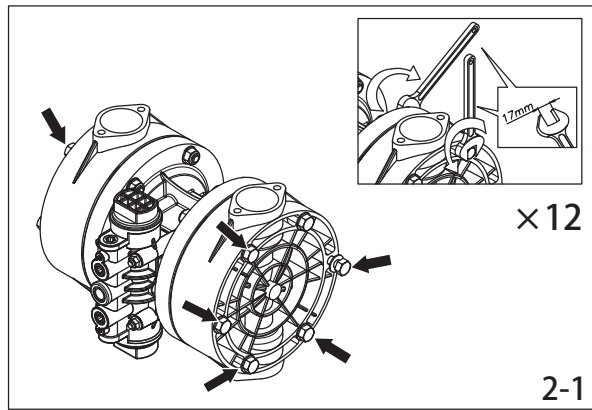

3

3-①

GC VE CC
 GN VV CN
 GE CE
 GV CV

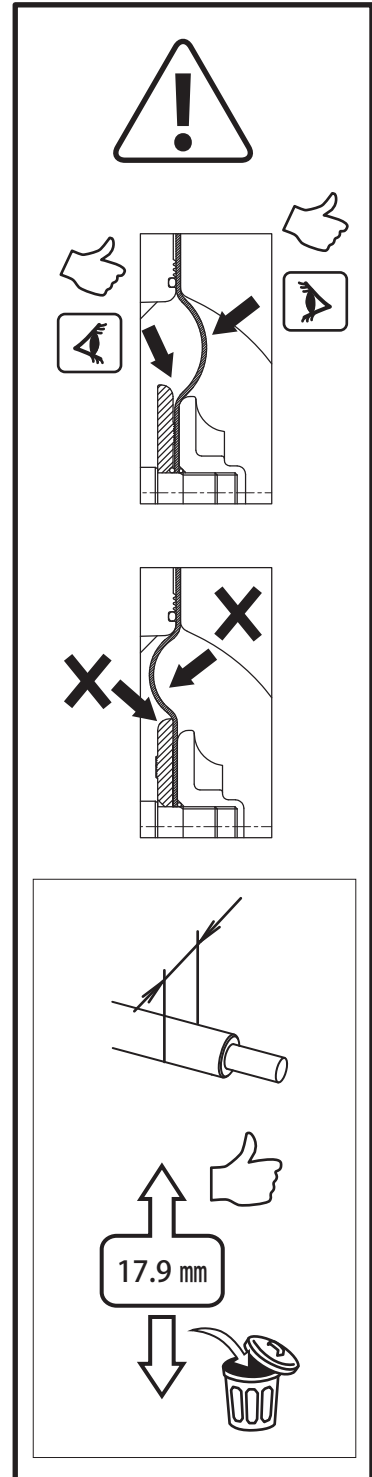
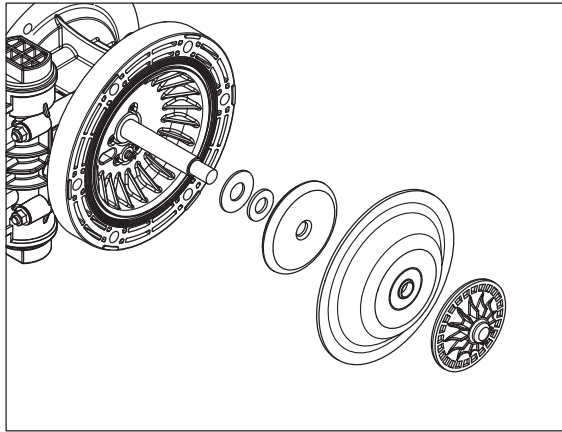

3-②

GH VH CH
 GS VS CS

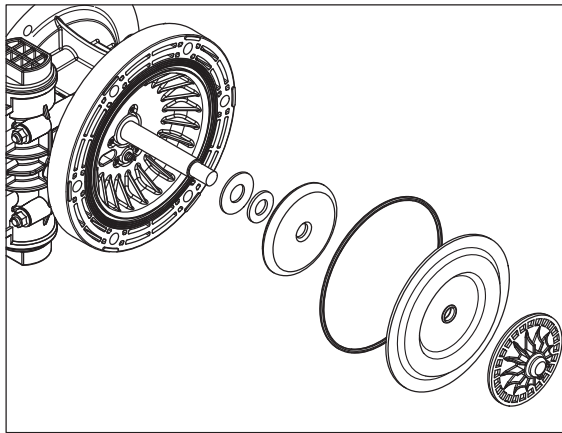

3-③

GT VT CT

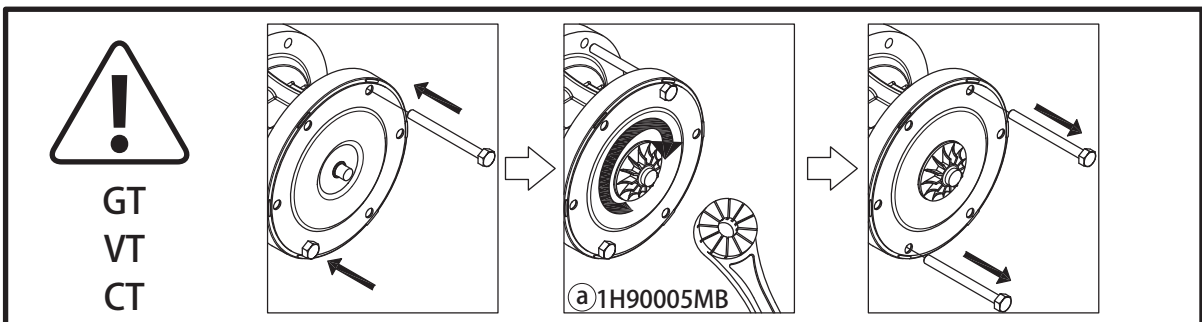
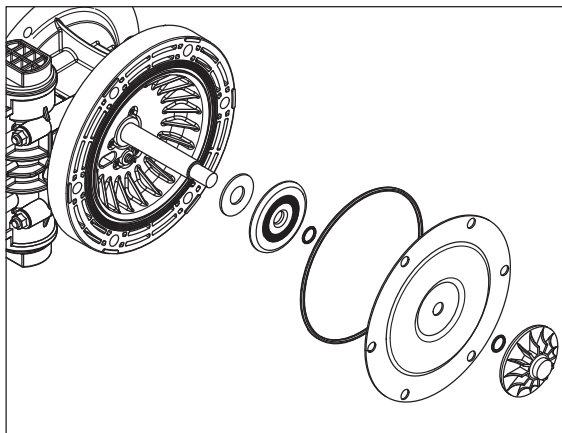

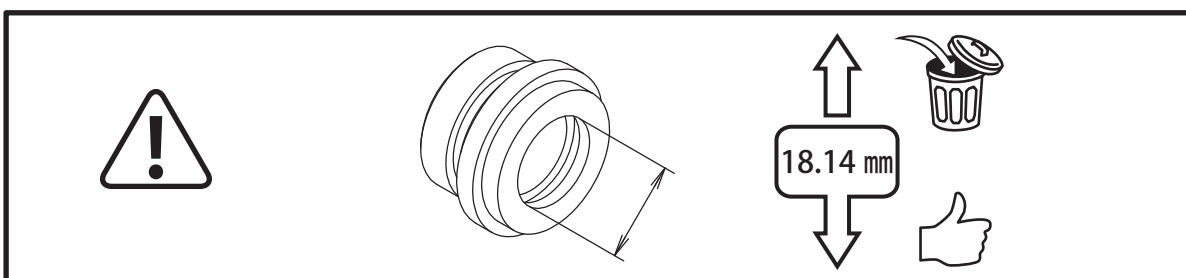
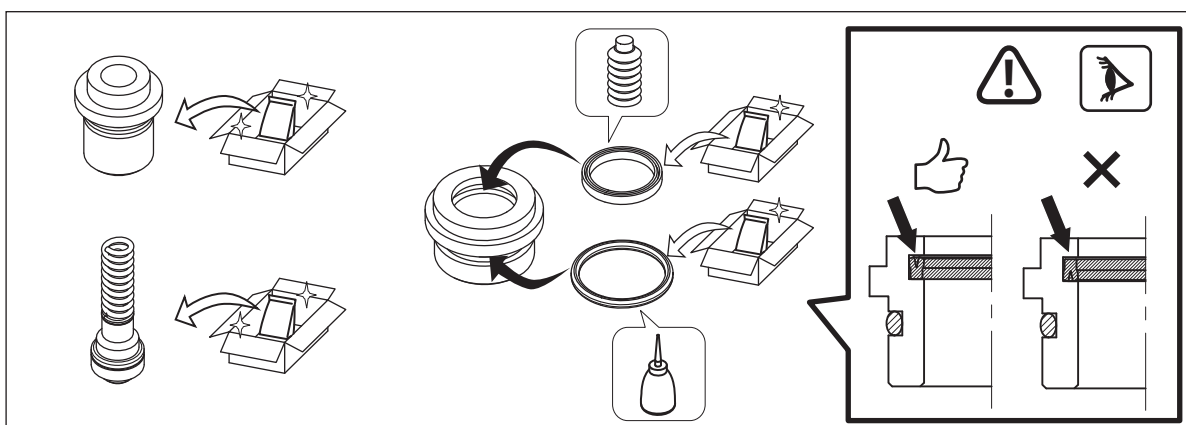
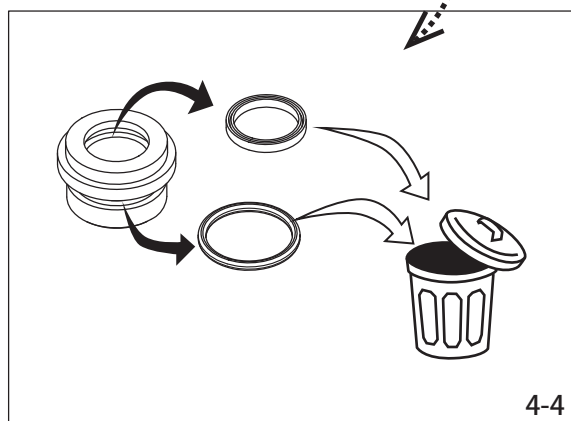
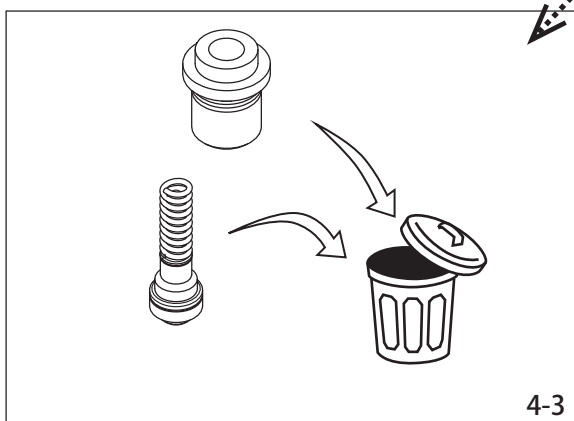
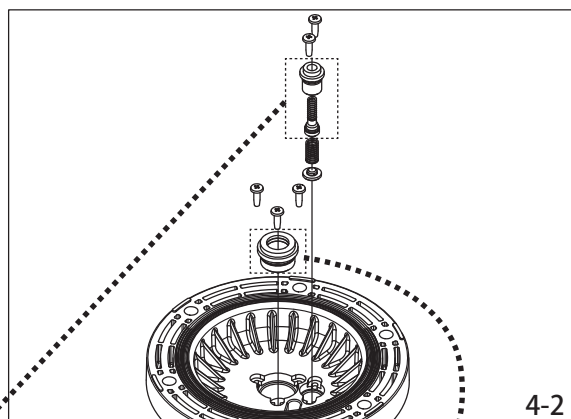
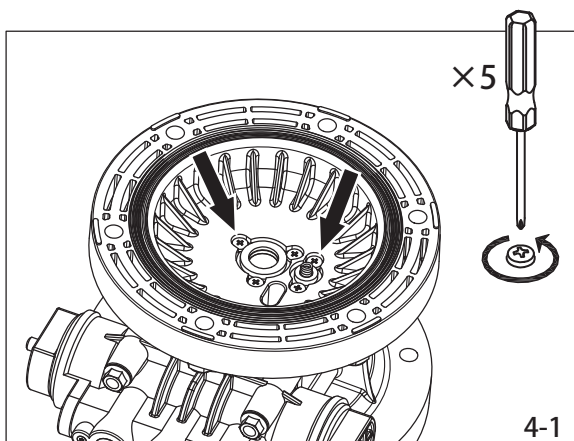

5

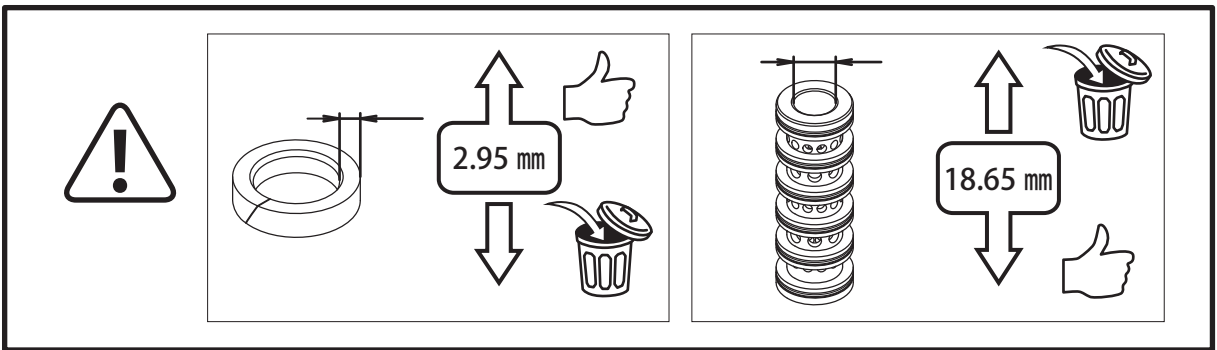
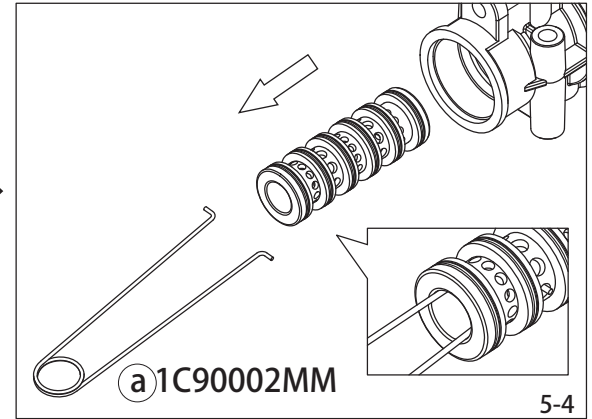
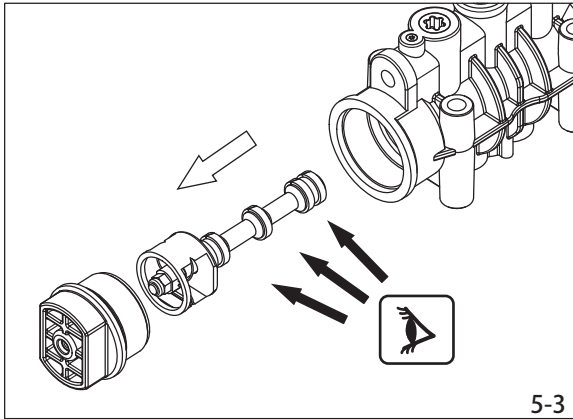
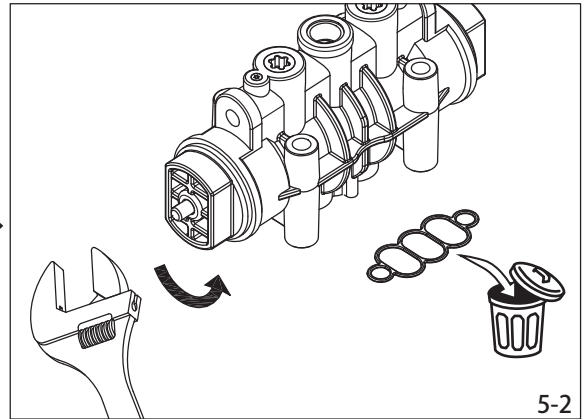
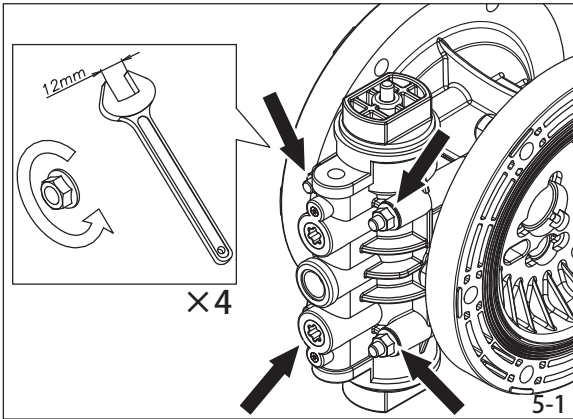

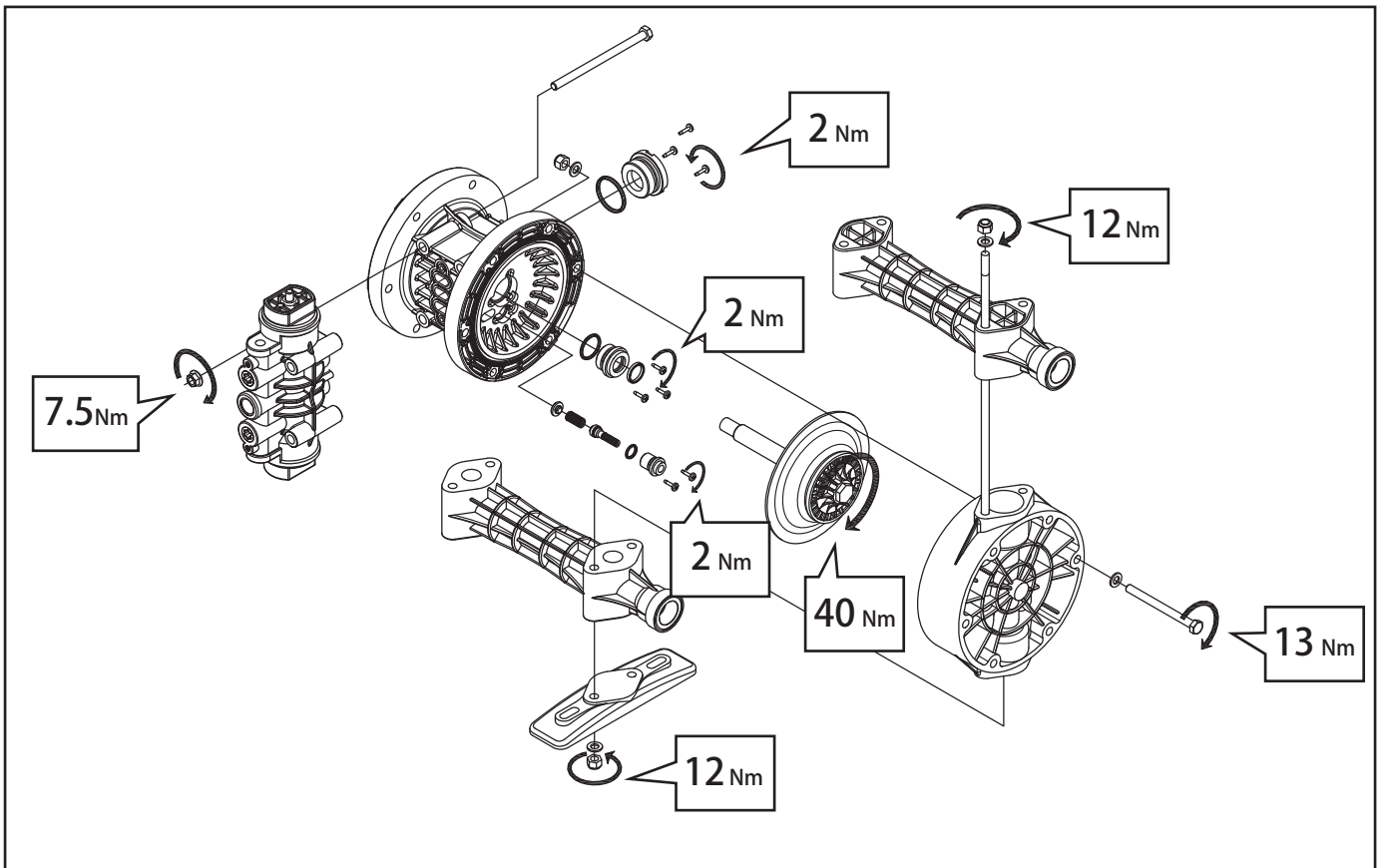
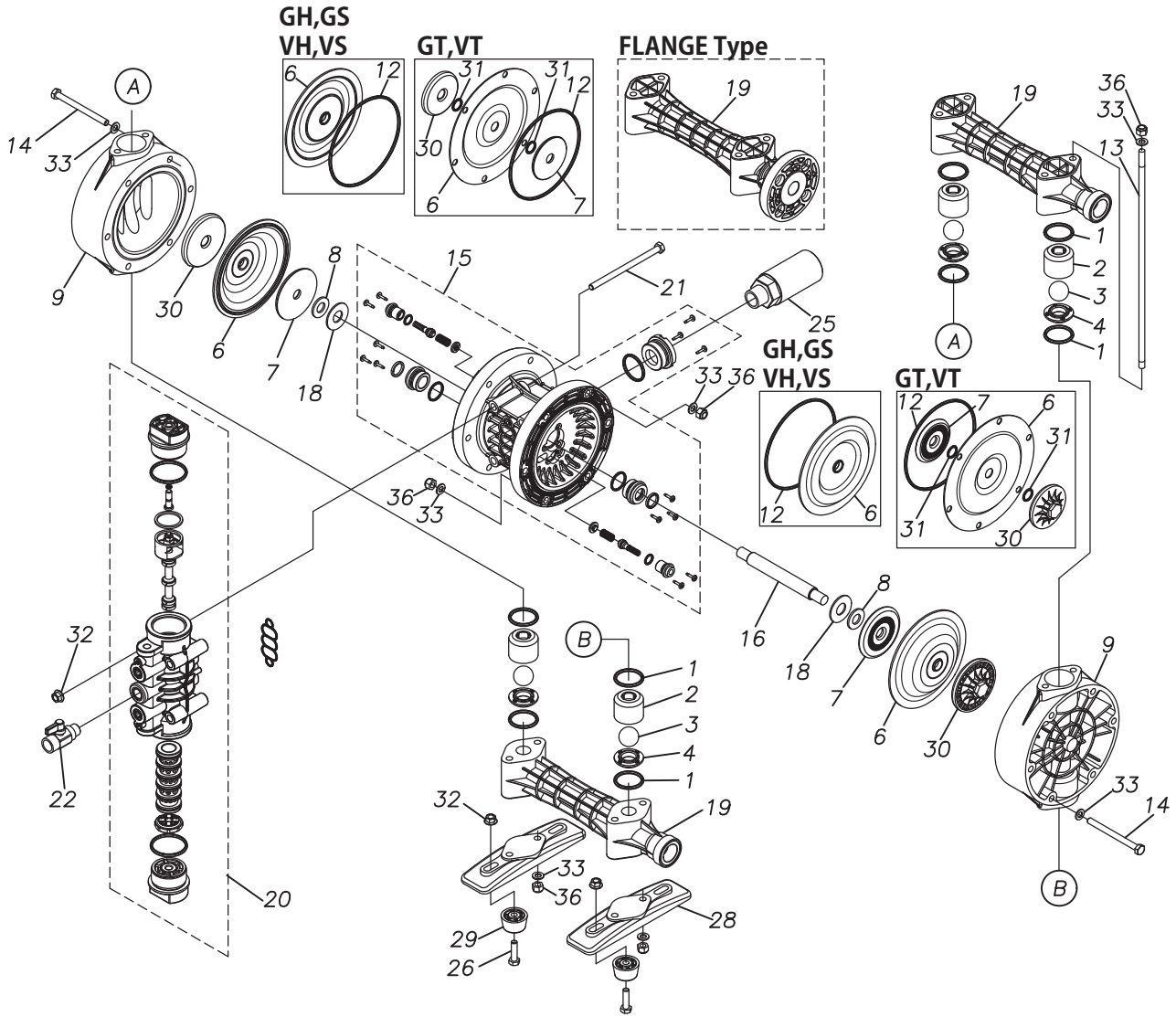

6

250G □ 250V □ 250C □

6-2

