

SYM	DWG.NO	CHANGE NO	DATE	REV'D BY
△	ALL	1HE0024	'16. 6.16	S.Murata
△	ALL	1BE0006 誤記訂正	'20. 6.23	K.Nakada

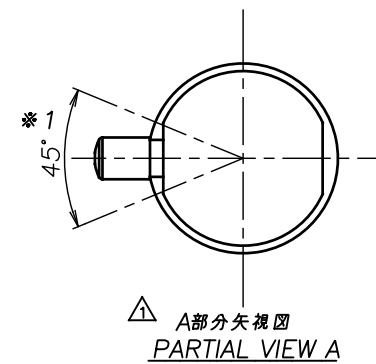
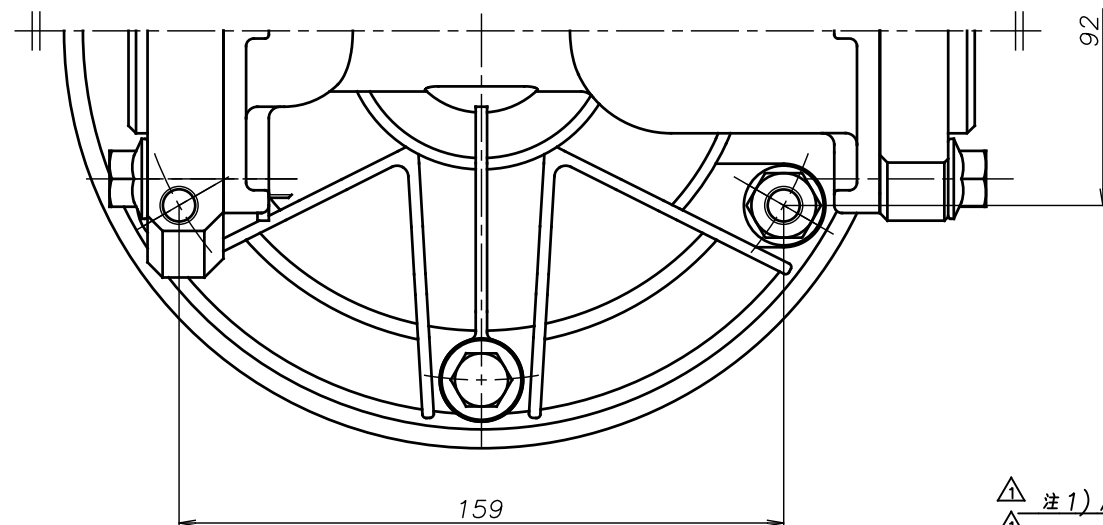
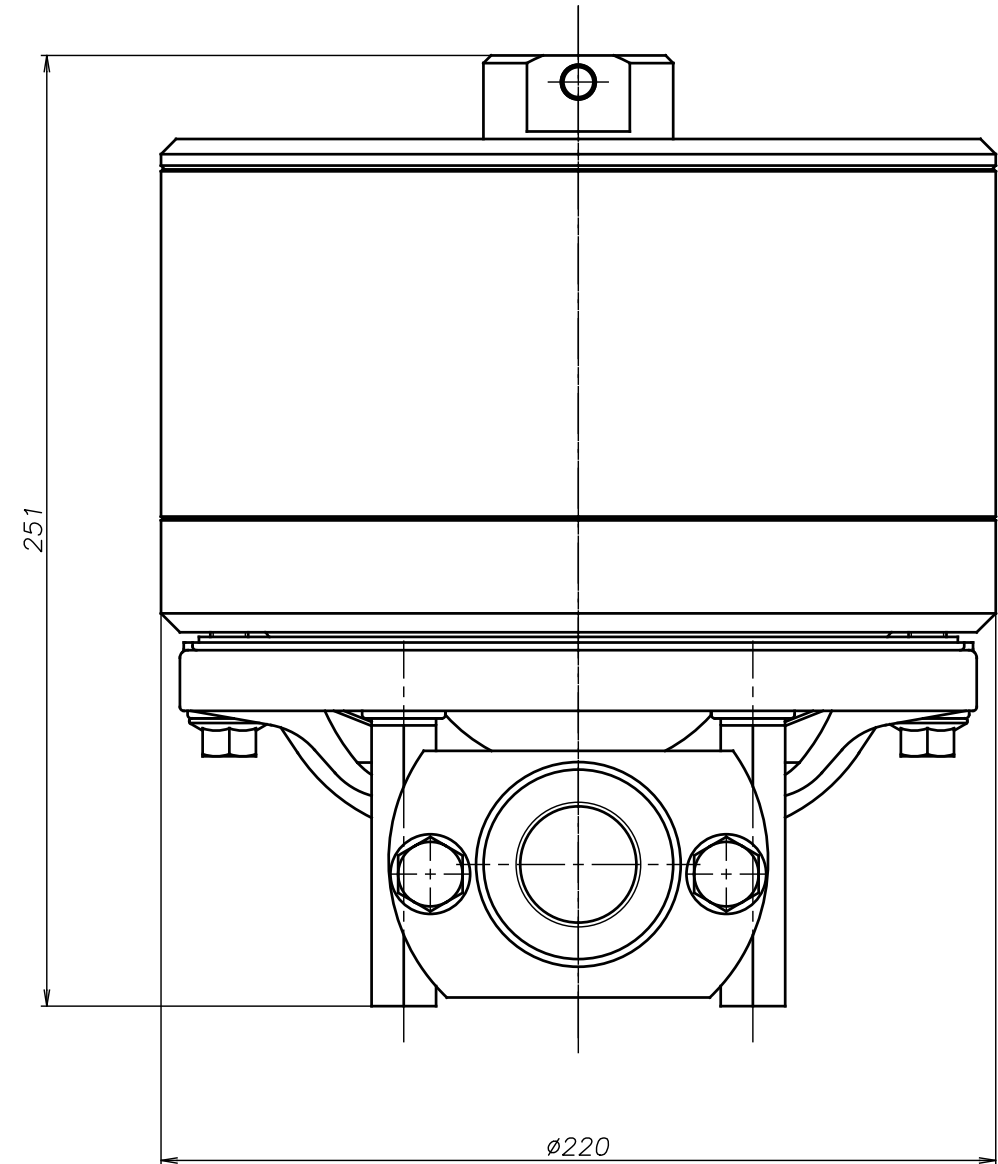
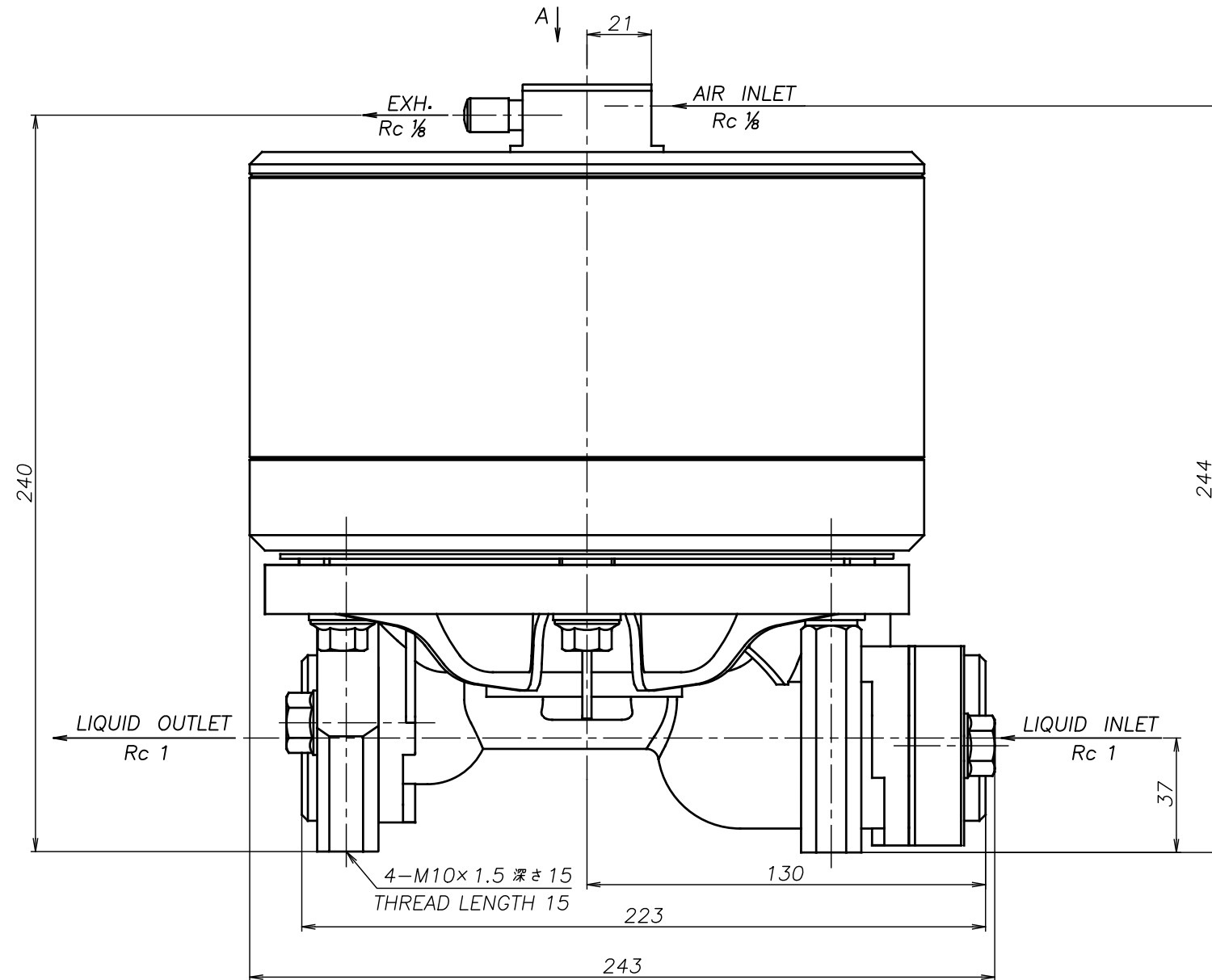

△ 注1) AIR INLET, EXH.は *1 の範囲で固定されています
 △ NOTE:1) AIR INLET & EXH. port are fixed in the range of *1.

CF-X25SS	THIRD ANG. PROJ.	DWG.NO.
	SCALE Free	1H00339YP-B
CF-X25SH	THIRD ANG. PROJ.	DWG.NO.
	SCALE Free	1H00338YP-B
CF-X25ST	THIRD ANG. PROJ.	DWG.NO.
	SCALE Free	1H00337YP-B
CF-X25SV	THIRD ANG. PROJ.	DWG.NO.
	SCALE Free	1H00336YP-B
CF-X25SE	THIRD ANG. PROJ.	DWG.NO.
	SCALE Free	1H00335YP-B
CF-X25SN	THIRD ANG. PROJ.	DWG.NO.
	SCALE Free	1H00334YP-B

APP'D BY '20. 8.18 S.Murata
 CHECKED BY '20. 8.18 K.Nakano
 DRAWN BY '20. 8.18 K.Nakada

THE DWG. OF:
 ダンパアセンブリ
 DAMPER ASSEMBLY
 CF-X25SC
 THIRD ANG. PROJ. DWG.NO.
 SCALE Free 1H00333YP-B

YTS Co., Ltd JAPAN