

SYM	DWG.NO	CHANGE NO	DATE	REV'D BY
△	ALL	1ME0008	'16. 6.16	S.Murata
△	ALL	1BE0006 誤記訂正	'20. 6.23	K.Nakada

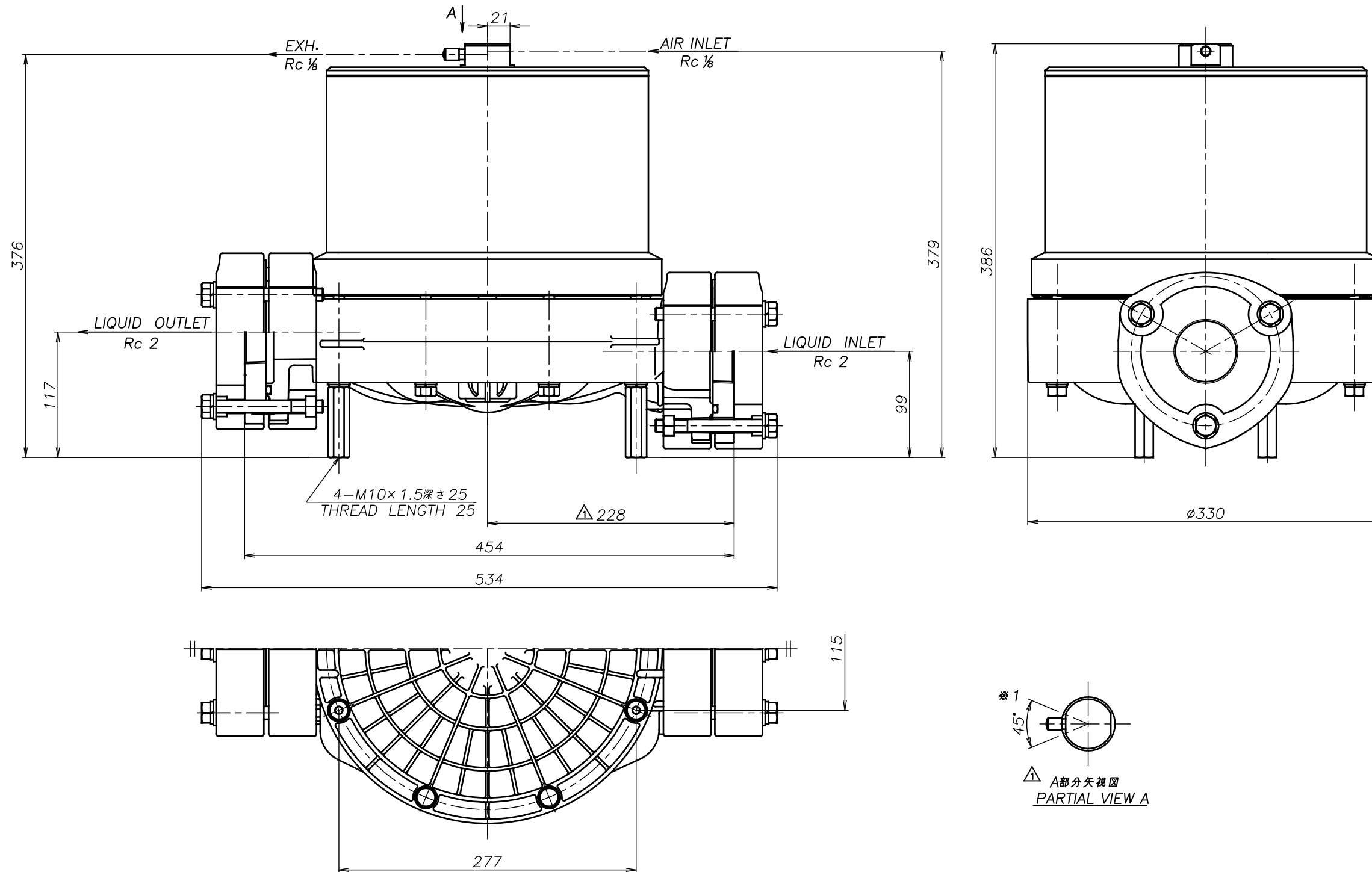

△ 注1) AIR INLET, EXH.は \*1 の範囲で固定されています  
 △ NOTE:1) AIR INLET & EXH. port are fixed in the range of \*1.

CF-X50VS		DWG.NO.	
THIRD ANG. PROJ.		1M00310YP-B	
SCALE Free			
APP'D BY	'20. 8.18 S.Murata	THE DWG. OF:	
CHECKED BY	'20. 8.18 K.Nakano	ダンパ アセンブリ	
DRAWN BY	'20. 8.18 K.Nakada	DAMPER ASSEMBLY	
YTS Co., Ltd JAPAN		CF-X50VT	
THIRD ANG. PROJ.		DWG.NO.	
SCALE Free		1M00308YP-B	