

SYM	DWG.NO	CHANGE NO	DATE	REV'D BY
△	ALL	1HE0008	'15. 4. 8	K.Nakada
△	ALL	1BE0005	'19.10.28	K.Nakada
△	ALL	1BE0006 異記訂正	'20. 6.23	K.Nakada

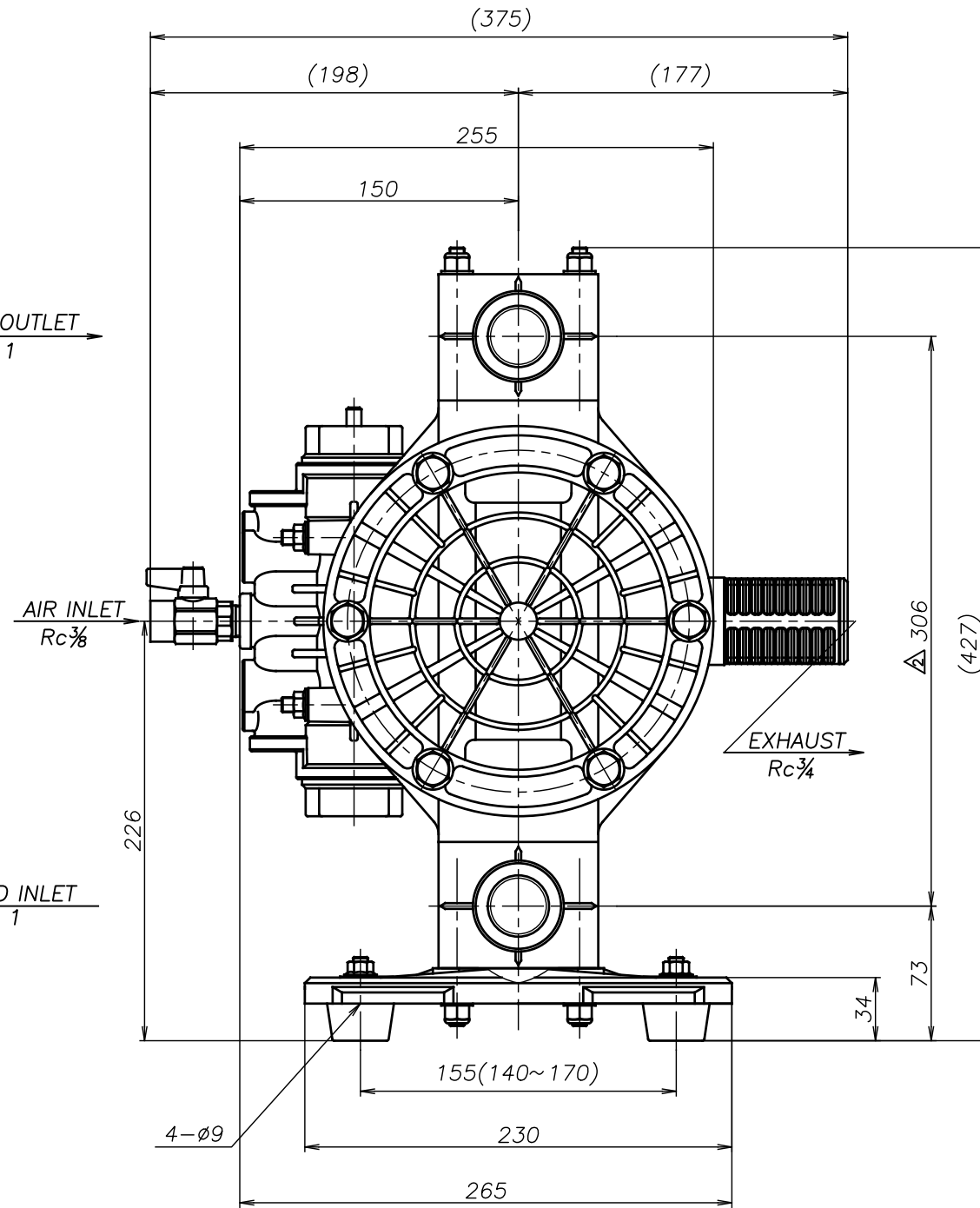
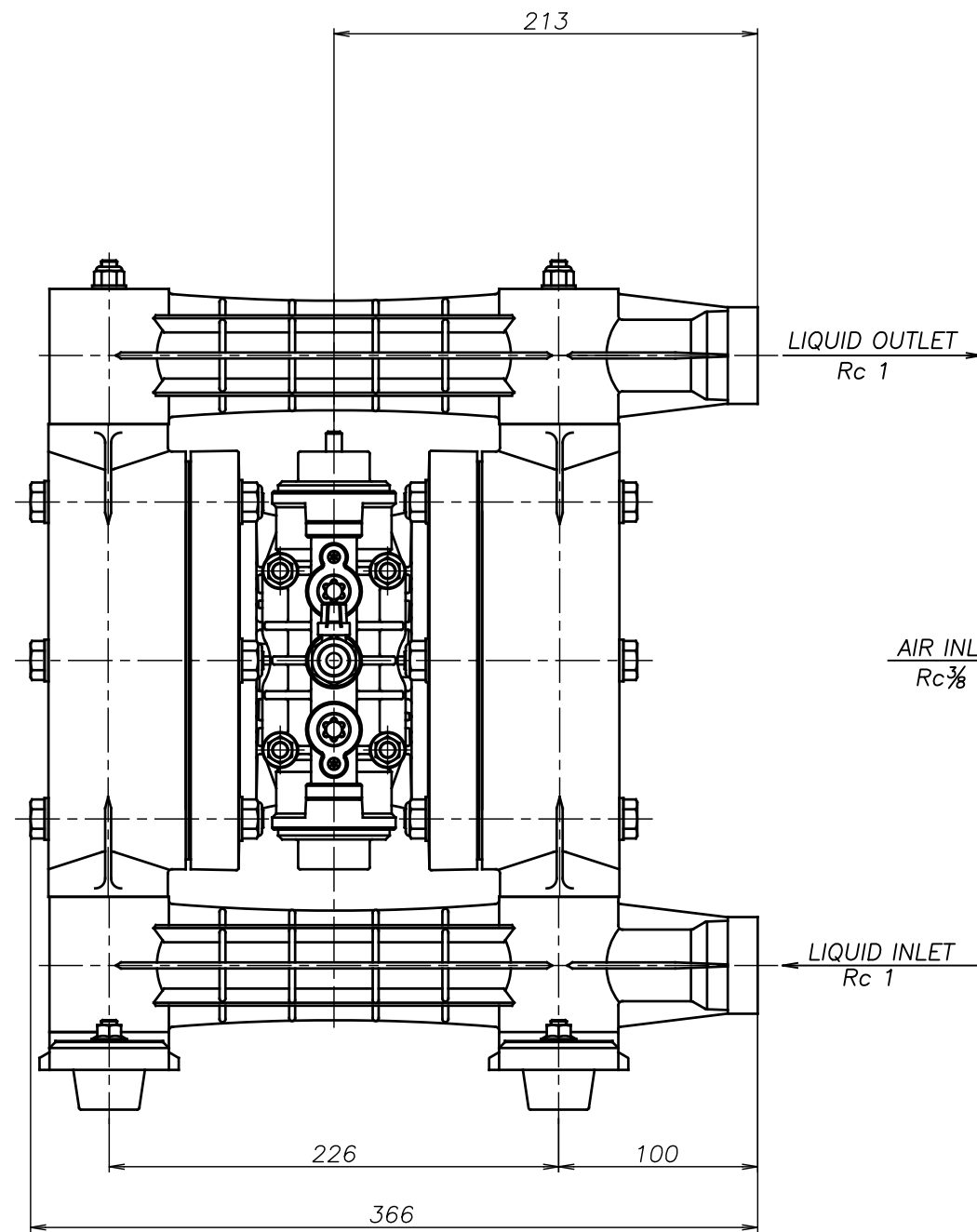

△TC-X250GS	THIRD ANG. PROJ.	DWG.NO.
	SCALE Free	1H00096YP-C
△TC-X250GH	THIRD ANG. PROJ.	DWG.NO.
	SCALE Free	1H00095YP-C
△TC-X250GT	THIRD ANG. PROJ.	DWG.NO.
	SCALE Free	1H00094YP-C
△TC-X250GV	THIRD ANG. PROJ.	DWG.NO.
	SCALE Free	1H00093YP-C
△TC-X250GE	THIRD ANG. PROJ.	DWG.NO.
	SCALE Free	1H00092YP-C
△TC-X250GN	THIRD ANG. PROJ.	DWG.NO.
	SCALE Free	1H00091YP-C

APP'D BY	'20. 8.18	S.Murata	THE DWG. OF:
CHECKED BY	'20. 8.18	K.Nakano	ダイヤフラムポンプアセンブリ
DRAWN BY	'20. 8.18	K.Nakada	DIAPHRAGM PUMP ASSEMBLY
			△TC-X250GC
<b>YTS</b> CORPORATION JAPAN			THIRD ANG. PROJ.
			DWG.NO.
			SCALE Free
			1H00090YP-C