

SYM	DWG.NO	CHANGE NO	DATE	REV'D BY
△	ALL	1ME0006	'16. 2.23	K.Nakada
△	ALL	1BE0005	'19.10.28	K.Nakada
△	ALL	1BE0006 異記訂正	'20. 6.23	K.Nakada

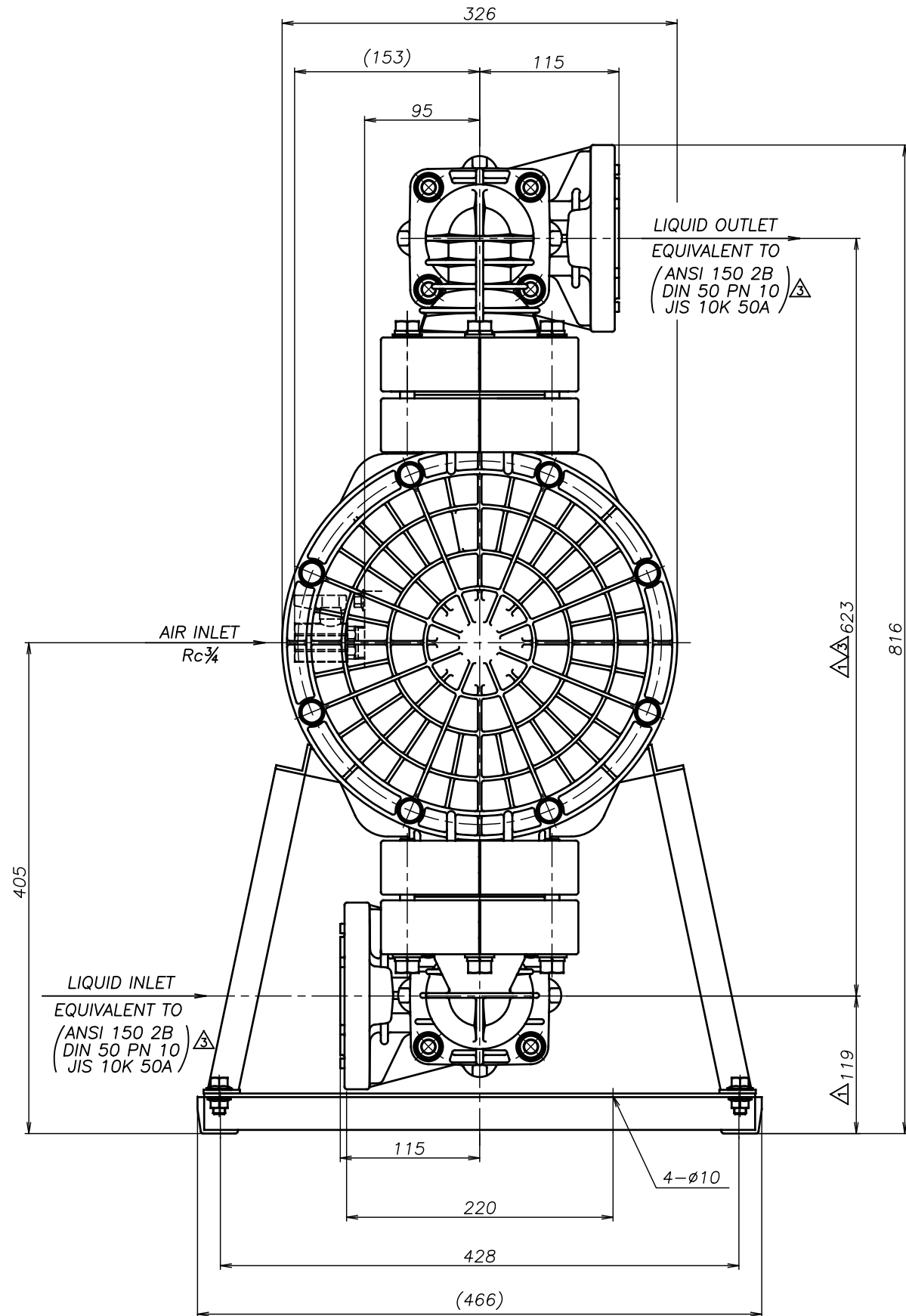
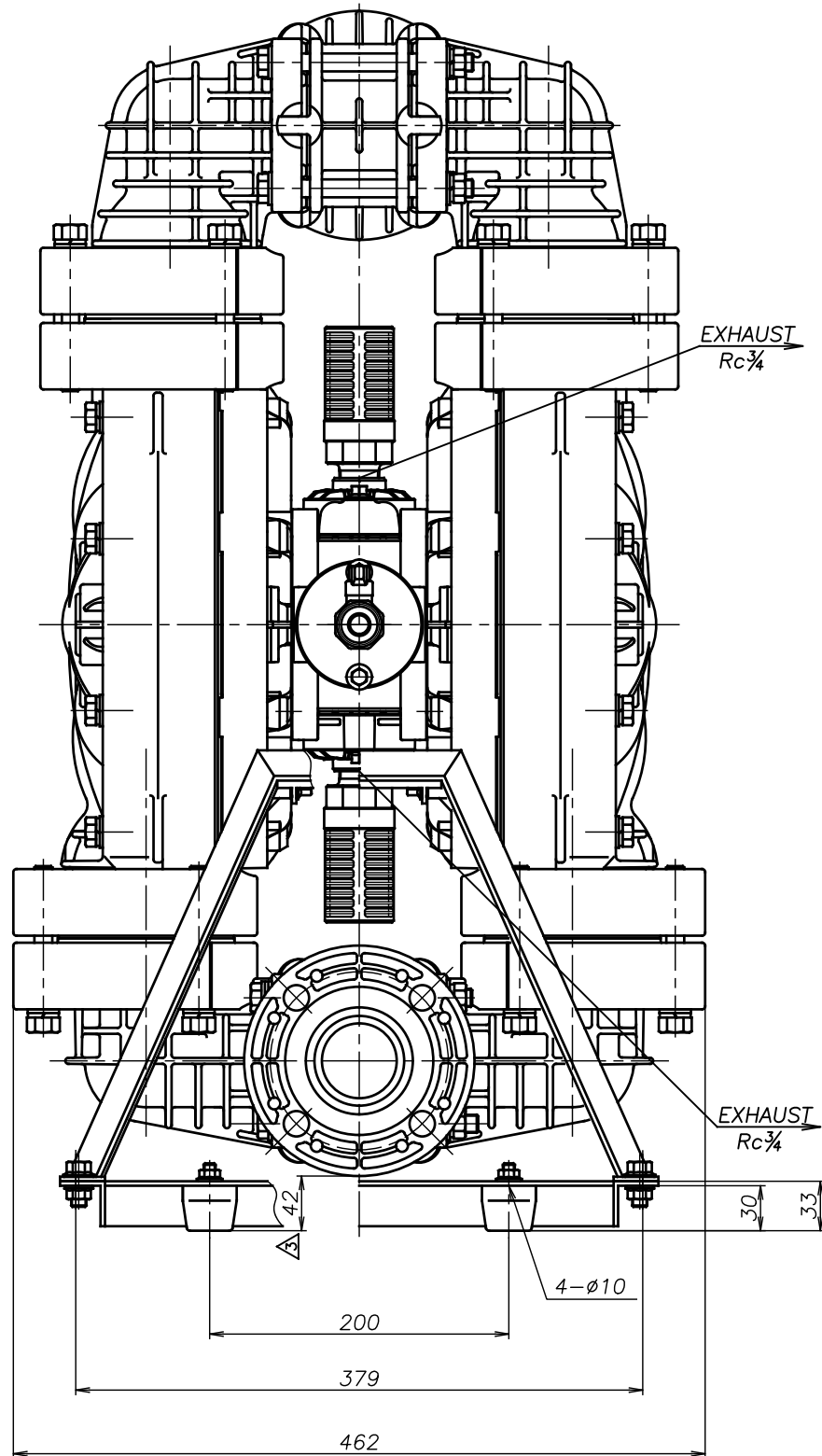

△TC-X500VSJ-M	THIRD ANG. PROJ.	DWG.NO.
SCALE Free		1M00101YP-D
△TC-X500VHJ-M	THIRD ANG. PROJ.	DWG.NO.
SCALE Free		1M00100YP-D
△TC-X500VTJ-M	THIRD ANG. PROJ.	DWG.NO.
SCALE Free		1M00099YP-D
△TC-X500VJJ-M	THIRD ANG. PROJ.	DWG.NO.
SCALE Free		1M00098YP-D

APP'D BY '20. 8.18	S.Murata	THE DWG. OF:
CHECKED BY '20. 8.18	K.Nakano	ダイアフラムポンプアセンブリ
DRAWN BY '20. 8.18	K.Nakada	DIAPHRAGM PUMP ASSEMBLY
		△TC-X500VEJ-M
		THIRD ANG. PROJ.
		DWG.NO.
		SCALE Free
		1M00097YP-D

YTS Co., Ltd JAPAN