

SYM	DWG.NO	CHANGE NO	DATE	REV'D BY
△	ALL	1PE0003	'15.12.21	S.Murata
△	ALL	1BE0005	'19.10.28	K.Nakada
△	ALL	1BE0006 異記訂正	'20. 6.23	K.Nakada

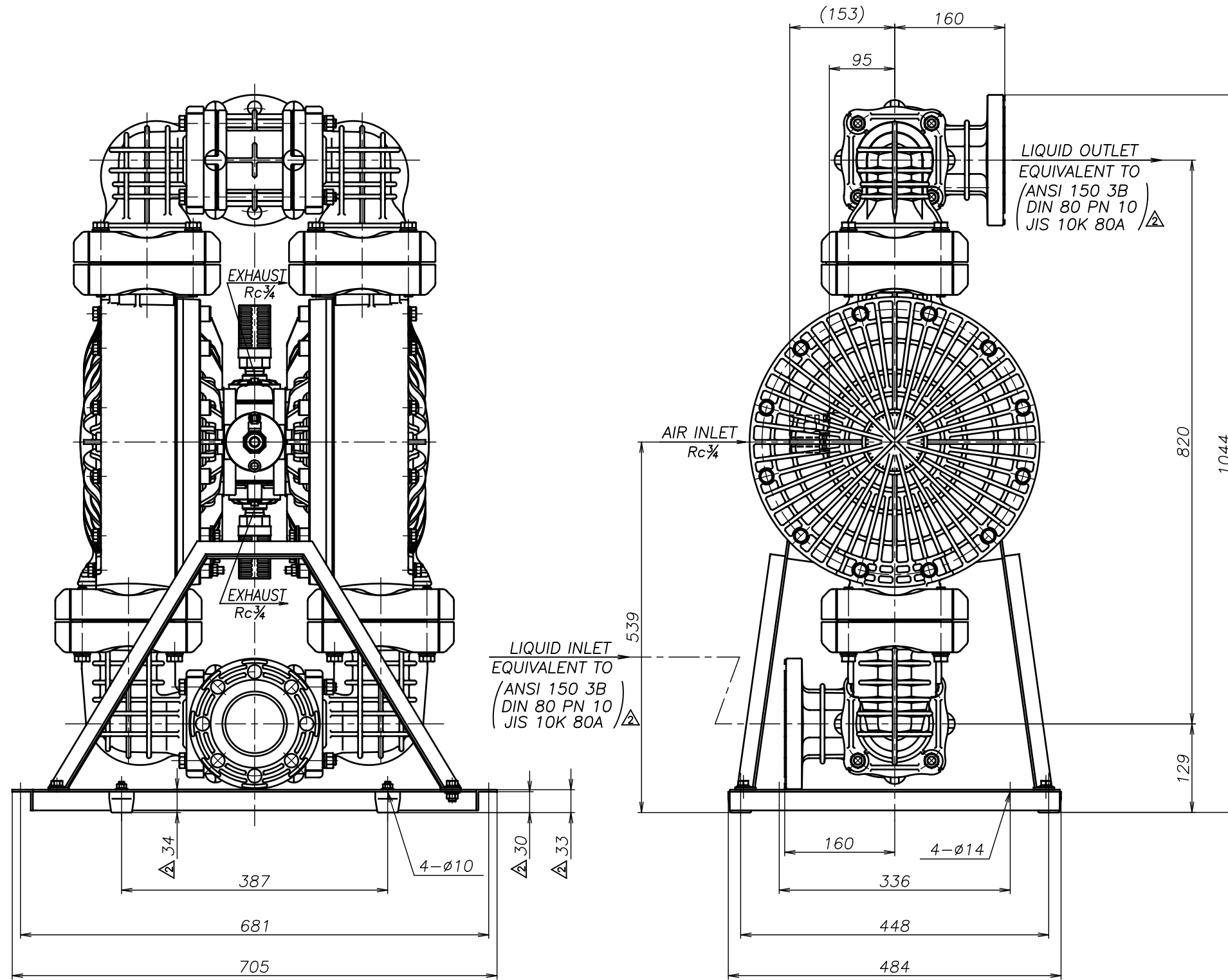

△TC-X800GSJ-M	THIRD ANG. PROJ.	DWG.NO.
SCALE Free		1P00084YP-C
△TC-X800GHJ-M	THIRD ANG. PROJ.	DWG.NO.
SCALE Free		1P00083YP-C
△TC-X800GTJ-M	THIRD ANG. PROJ.	DWG.NO.
SCALE Free		1P00082YP-C
△TC-X800GVJ-M	THIRD ANG. PROJ.	DWG.NO.
SCALE Free		1P00081YP-C
△TC-X800GEJ-M	THIRD ANG. PROJ.	DWG.NO.
SCALE Free		1P00080YP-C
△TC-X800GNJ-M	THIRD ANG. PROJ.	DWG.NO.
SCALE Free		1P00079YP-C

APP'D BY	'20. 8.18	S.Murata	THE DWG. OF:
CHECKED BY	'20. 8.18	K.Nakano	ダイアフラムポンプアセンブリ
DRAWN BY	'20. 8.18	K.Nakada	DIAPHRAGM PUMP ASSEMBLY
			△TC-X800GCJ-M
			THIRD ANG. PROJ.
			DWG.NO.
			SCALE Free
			1P00078YP-C

YTS Co., Ltd JAPAN