

SYM	DWG.NO	CHANGE NO	DATE	REV'D BY
△	ALL	1HE0057	'19. 5.31	K.Nakada
△	ALL	1BE0005	'19.10.28	K.Nakada
△	ALL	1BE0006 異記訂正	'20. 6.23	K.Nakada

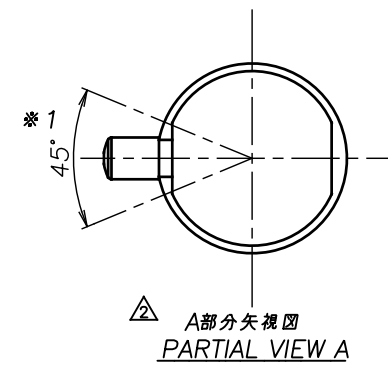
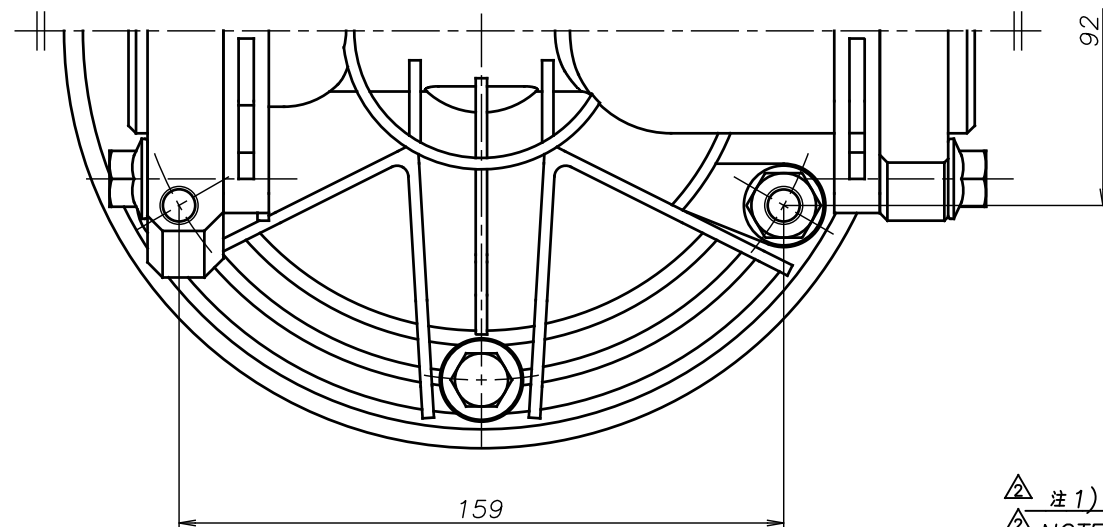
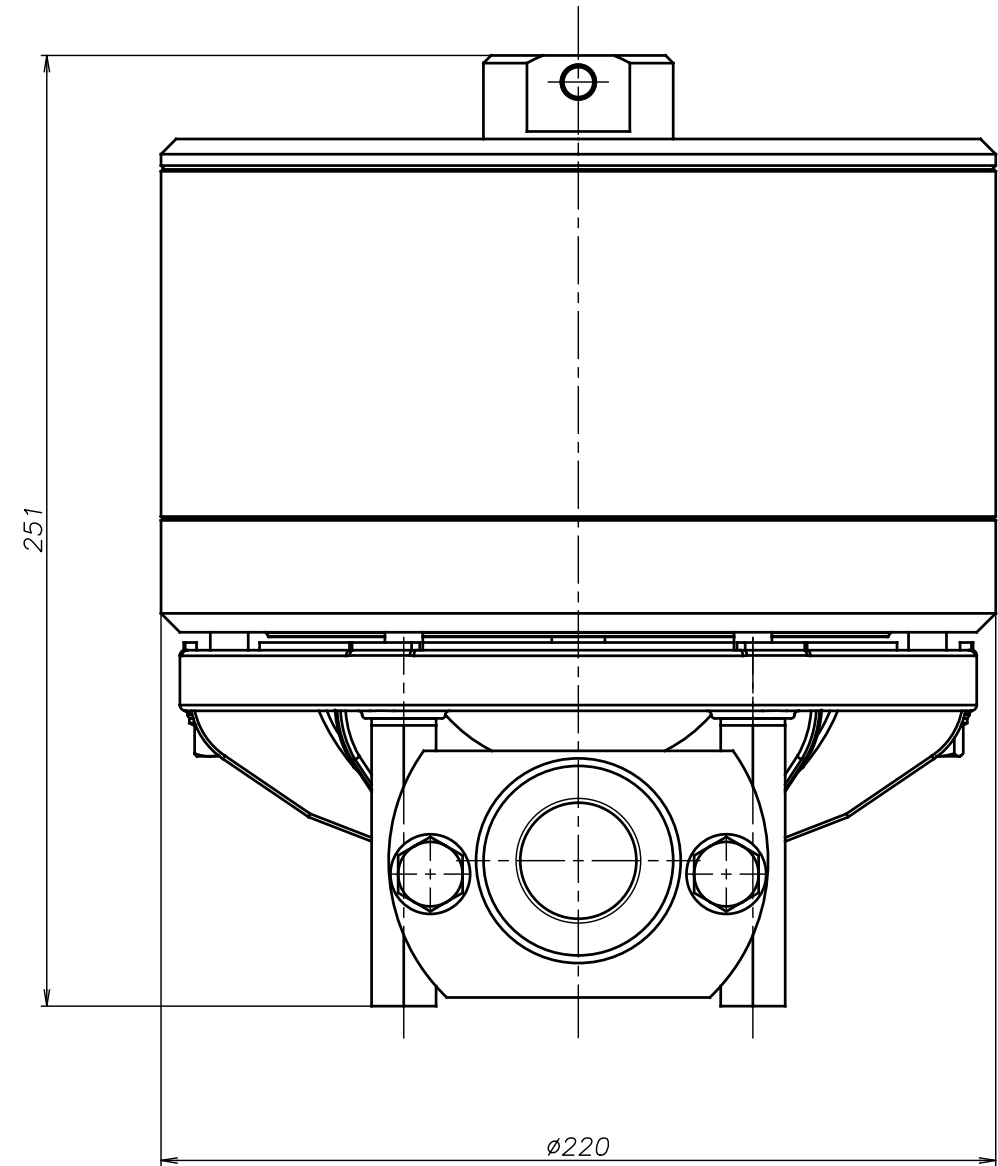
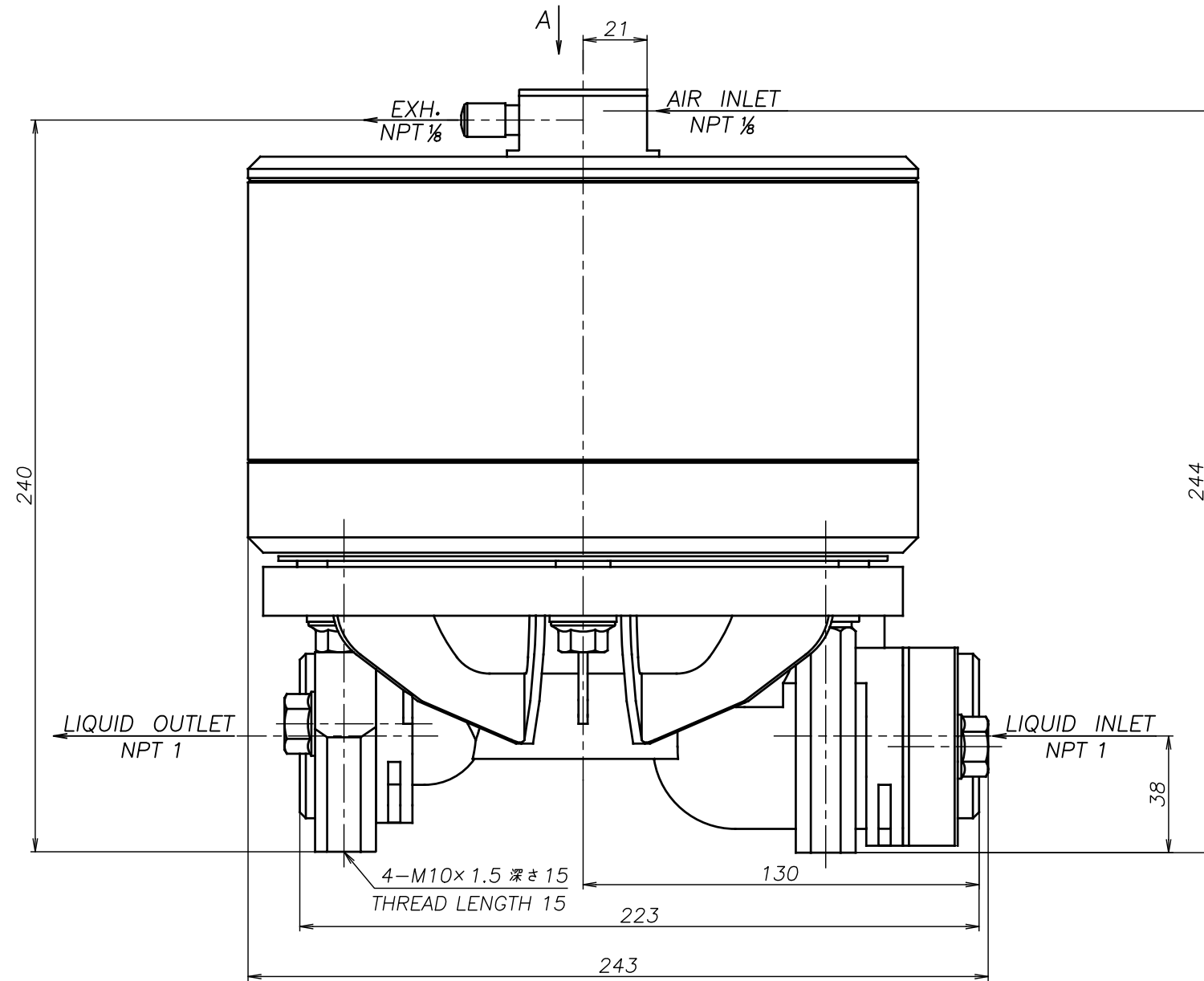

△ 注1) AIR INLET, EXH.は *1 の範囲で固定されています
△ NOTE:1) AIR INLET & EXH. port are fixed in the range of *1.

△CF-X25ASN	THIRD ANG. PROJ.	DWG.NO.	1H00332YN-C
	SCALE	Free	
△CF-X25AHN	THIRD ANG. PROJ.	DWG.NO.	1H00331YN-C
	SCALE	Free	
△CF-X25ATN	THIRD ANG. PROJ.	DWG.NO.	1H00330YN-C
	SCALE	Free	
△CF-X25AVN	THIRD ANG. PROJ.	DWG.NO.	1H00329YN-C
	SCALE	Free	
△CF-X25AEN	THIRD ANG. PROJ.	DWG.NO.	1H00328YN-C
	SCALE	Free	
△CF-X25ANN	THIRD ANG. PROJ.	DWG.NO.	1H00327YN-C
	SCALE	Free	
APP'D BY '20. 8.18 S.Murata	THE DWG. OF: ダンパアセンブリ DAMPER ASSEMBLY		
CHECKED BY '20. 8.18 K.Nakano	△CF-X25ACN		
DRAWN BY '20. 8.18 K.Nakada	THIRD ANG. PROJ.	DWG.NO.	1H00326YN-C
YTS Co., Ltd JAPAN	SCALE	Free	