

SYM	DWG.NO	CHANGE NO	DATE	REV'D BY
△	1C00026YN-A	1CE0014	'15. 4. 8	K.Nakada
△	1C00026YN-B	1CE0030	'18. 3.19	K.Nakada
△	1C00026YN-C	1BE0005	'19.10.28	K.Nakada

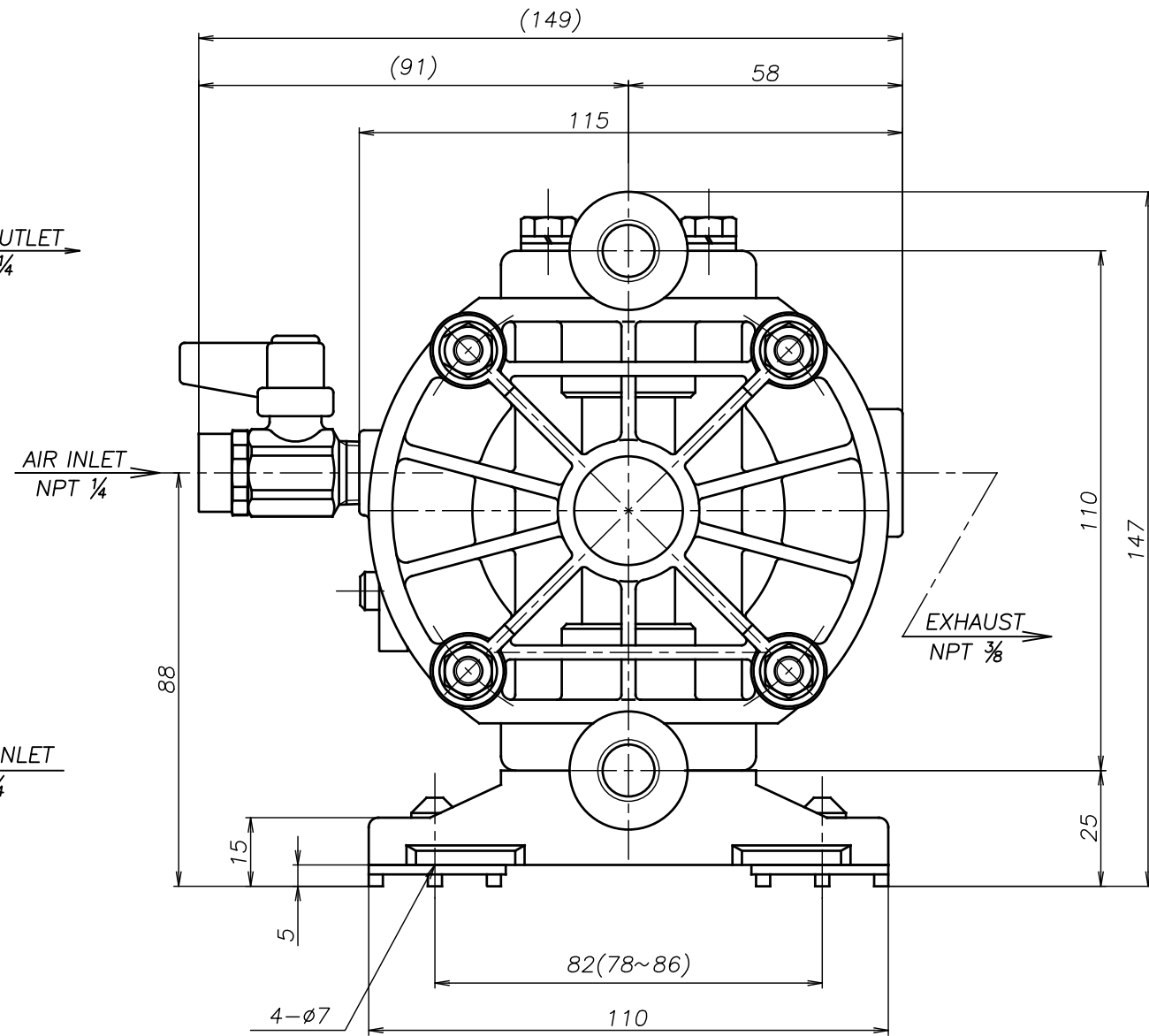
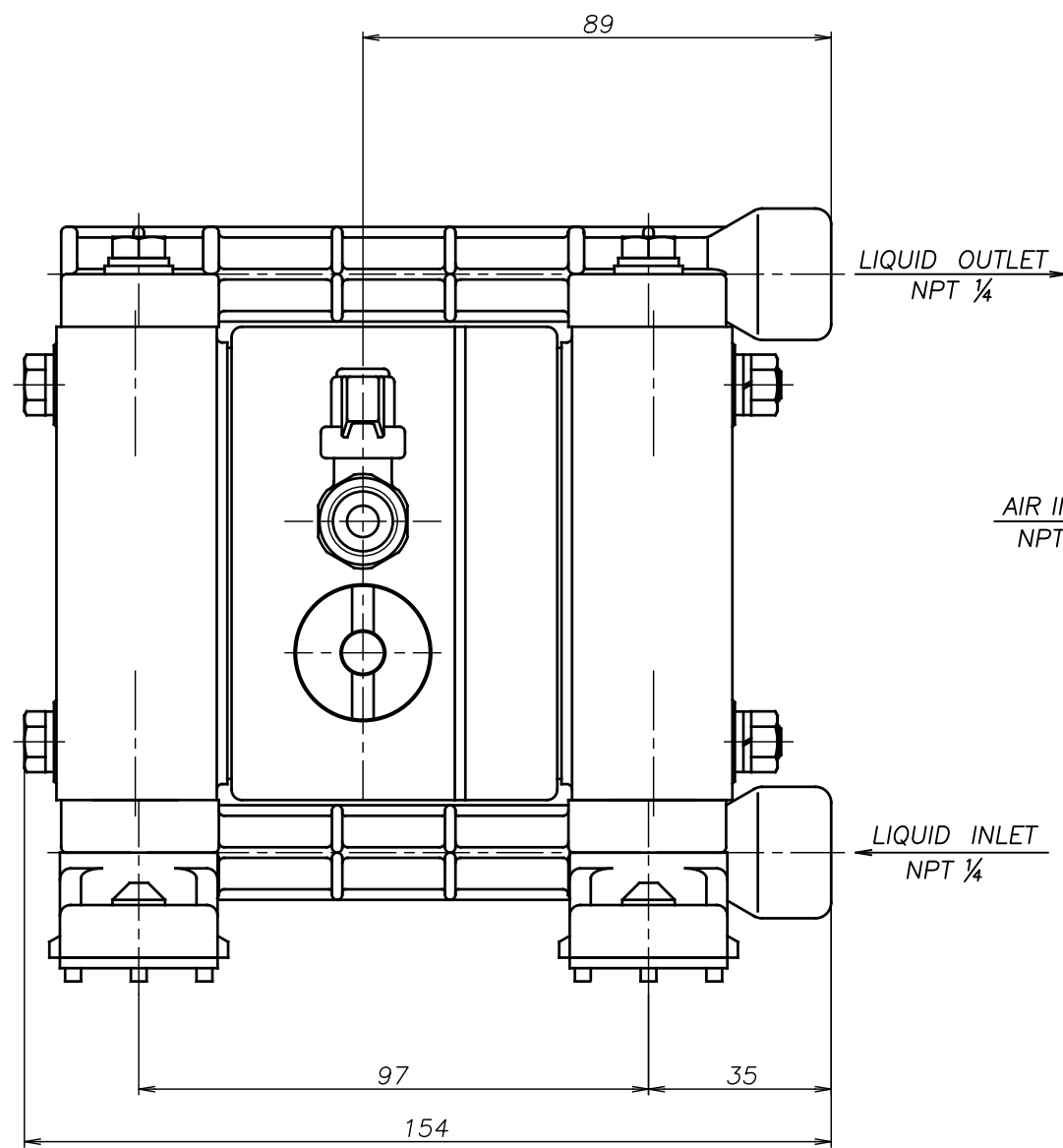

APP'D BY	'19.10.28 S.Murata	THE DWG. OF:	ダイアフラムポンプアセンブリ
CHECKED BY	'19.10.28 K.Nakano	DIAPHRAGM PUMP ASSEMBLY	
DRAWN BY	'19.10.28 K.Nakada	△TC-X050VTN	
YTS Co., Ltd JAPAN		THIRD ANG. PROJ.	DWG.NO.
		SCALE Free	1C00026YN-C