

SYM	DWG.NO	CHANGE NO	DATE	REV'D BY
△	ALL	1GE0006	'15. 8.27	K.Nakada
△	ALL	1BE0005	'19.10.28	K.Nakada
△	ALL	1BE0006 異記訂正	'20. 6.23	K.Nakada

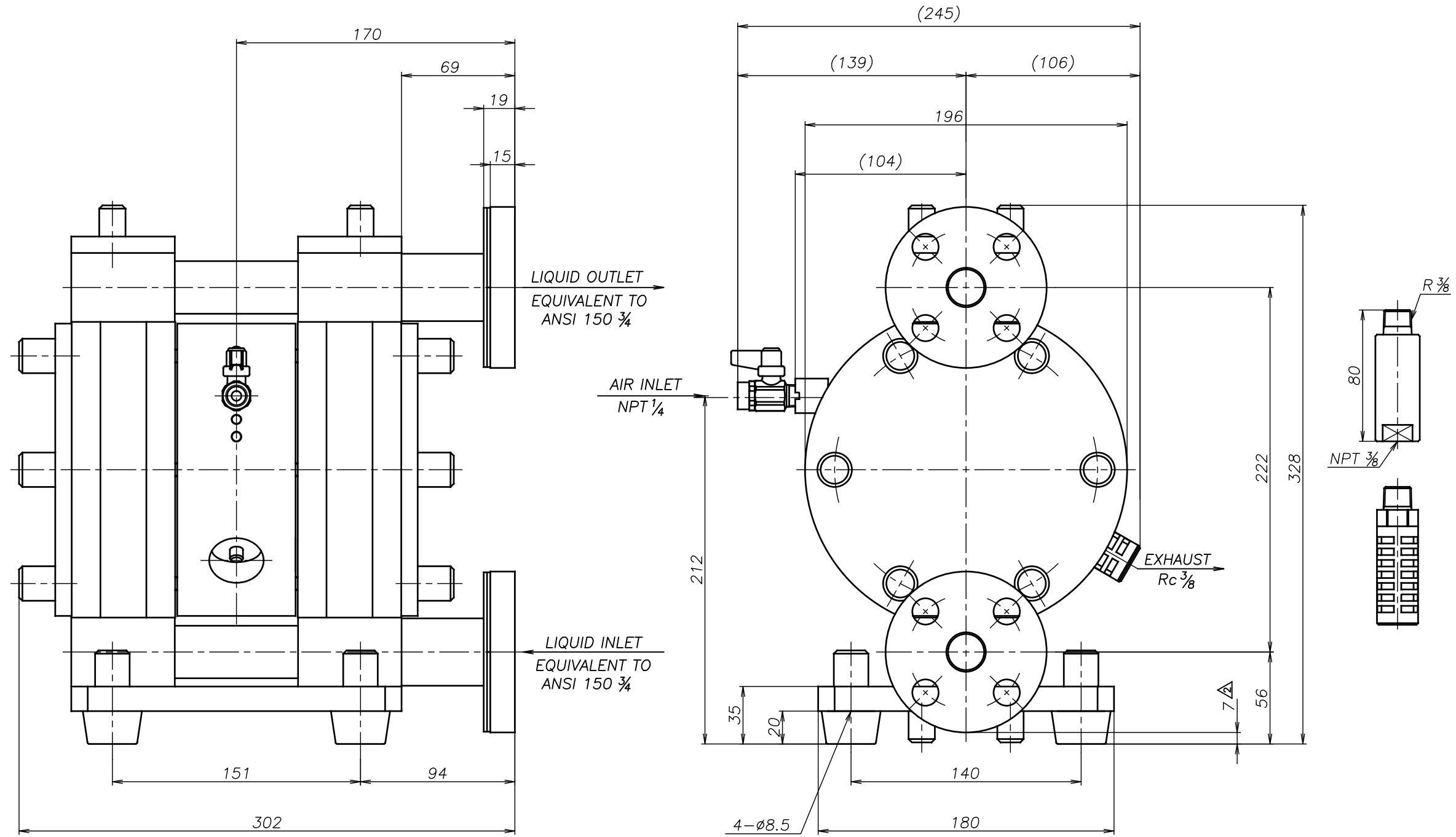

△TC-X200HTA-X		THIRD ANG. PROJ. DWG.NO.	
SCALE Free		1G00056YN-C	
APP'D BY	'20. 8.18 S.Murata	THE DWG. OF:	
CHECKED BY	'20. 8.18 K.Nakano	ダイアフラムポンプアセンブリ	
DRAWN BY	'20. 8.18 K.Nakada	DIAPHRAGM PUMP ASSEMBLY	
YTS Co., Ltd JAPAN		△TC-X200HTA	
THIRD ANG. PROJ. DWG.NO.		SCALE Free	
		1G00054YN-C	