

SYM	DWG.NO	CHANGE NO	DATE	REV'D BY
△	ALL	1HE0008	'15. 4. 8	K.Nakada
△	ALL	1BE0005	'19.10.28	K.Nakada
△	ALL	1BE0006 異記訂正	'20. 6.23	K.Nakada

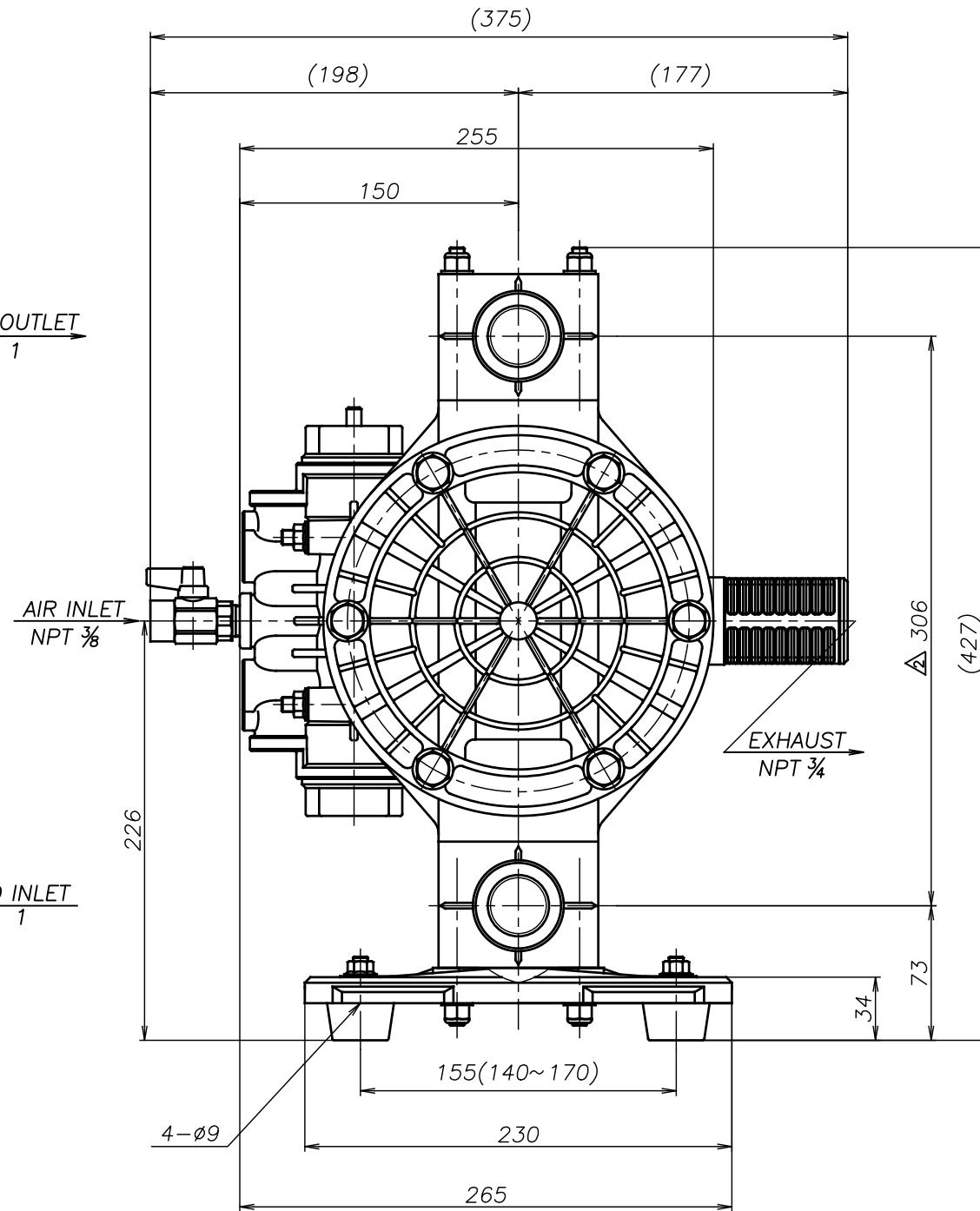
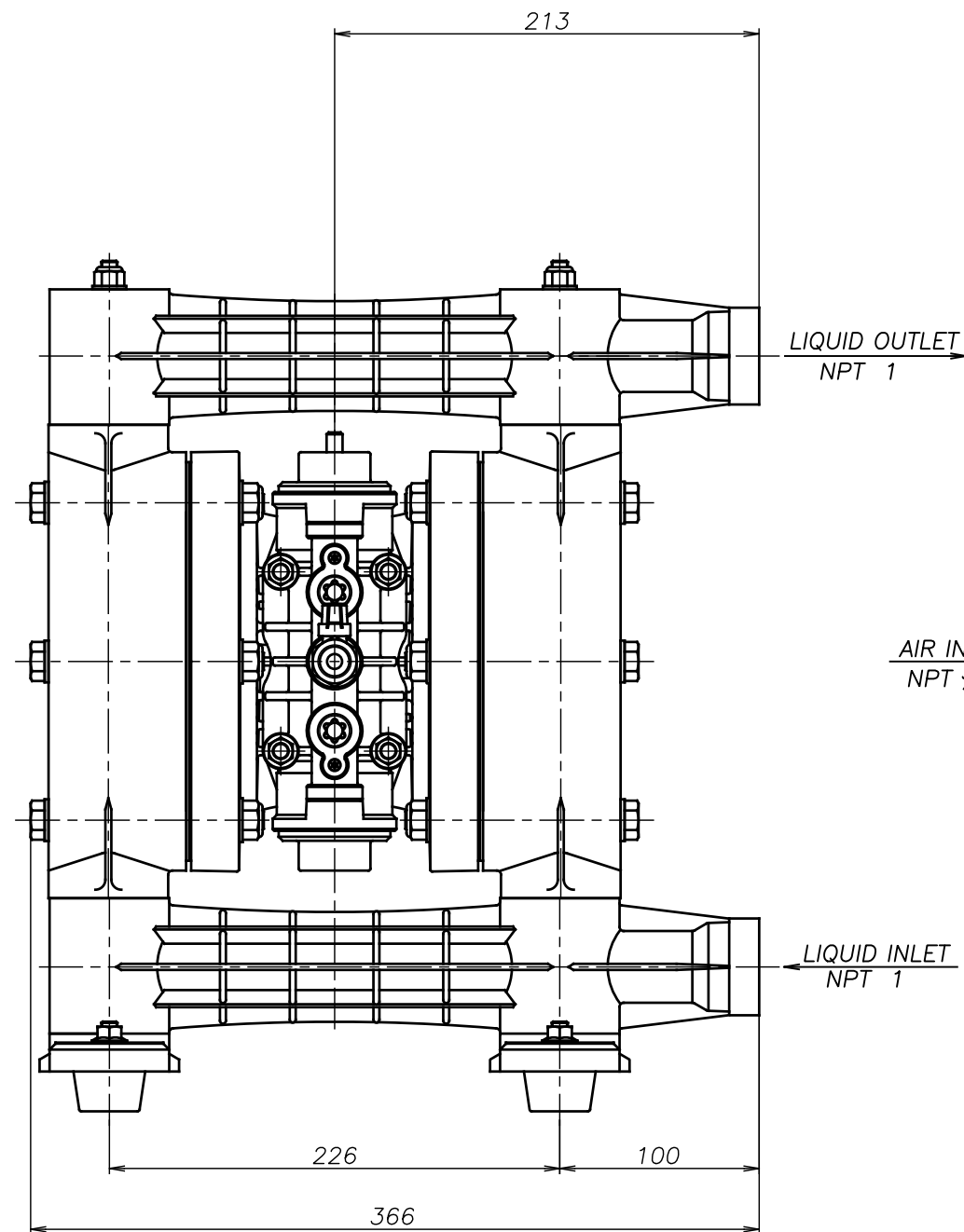

△TC-X250GSN	
THIRD ANG. PROJ.	DWG.NO.
SCALE Free	1H00096YN-C
△TC-X250GHN	
THIRD ANG. PROJ.	DWG.NO.
SCALE Free	1H00095YN-C
△TC-X250GTN	
THIRD ANG. PROJ.	DWG.NO.
SCALE Free	1H00094YN-C
△TC-X250GVN	
THIRD ANG. PROJ.	DWG.NO.
SCALE Free	1H00093YN-C
△TC-X250GEN	
THIRD ANG. PROJ.	DWG.NO.
SCALE Free	1H00092YN-C
△TC-X250GNN	
THIRD ANG. PROJ.	DWG.NO.
SCALE Free	1H00091YN-C

APP'D BY	'20. 8.18 S.Murata	THE DWG. OF:	ダイアフラムポンプアセンブリ
CHECKED BY	'20. 8.18 K.Nakano	DIAPHRAGM PUMP ASSEMBLY	
DRAWN BY	'20. 8.18 K.Nakada	△TC-X250GCN	
YTS CORPORATION JAPAN		THIRD ANG. PROJ.	DWG.NO.
		SCALE Free	1H00090YN-C