

SYM	DWG.NO	CHANGE NO	DATE	REV'D BY
△	ALL	1HE0008	'15. 4. 8	K.Nakada
△	ALL	1BE0005	'19.10.28	K.Nakada
△	ALL	1BE0006 異記訂正	'20. 6.23	K.Nakada

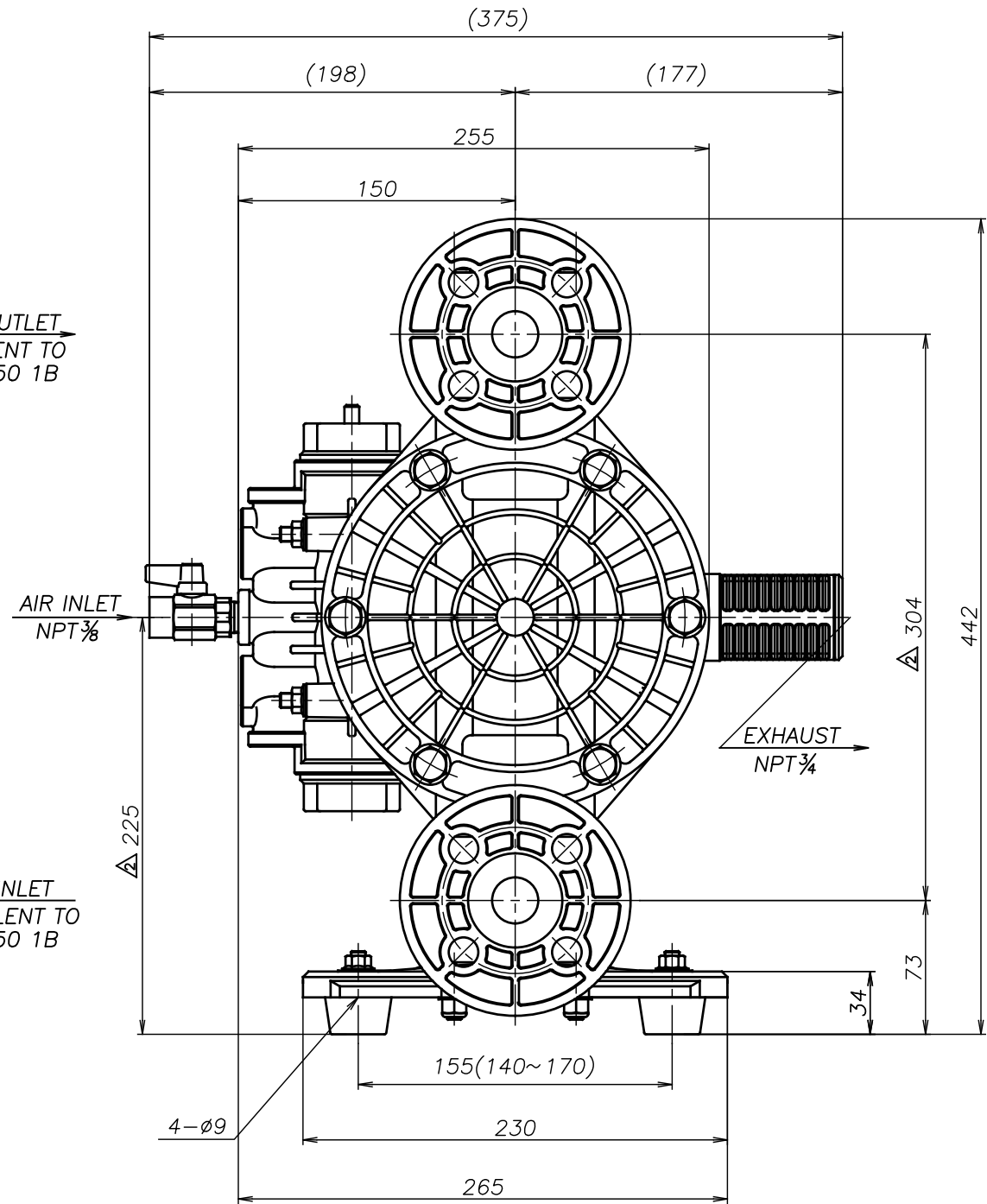
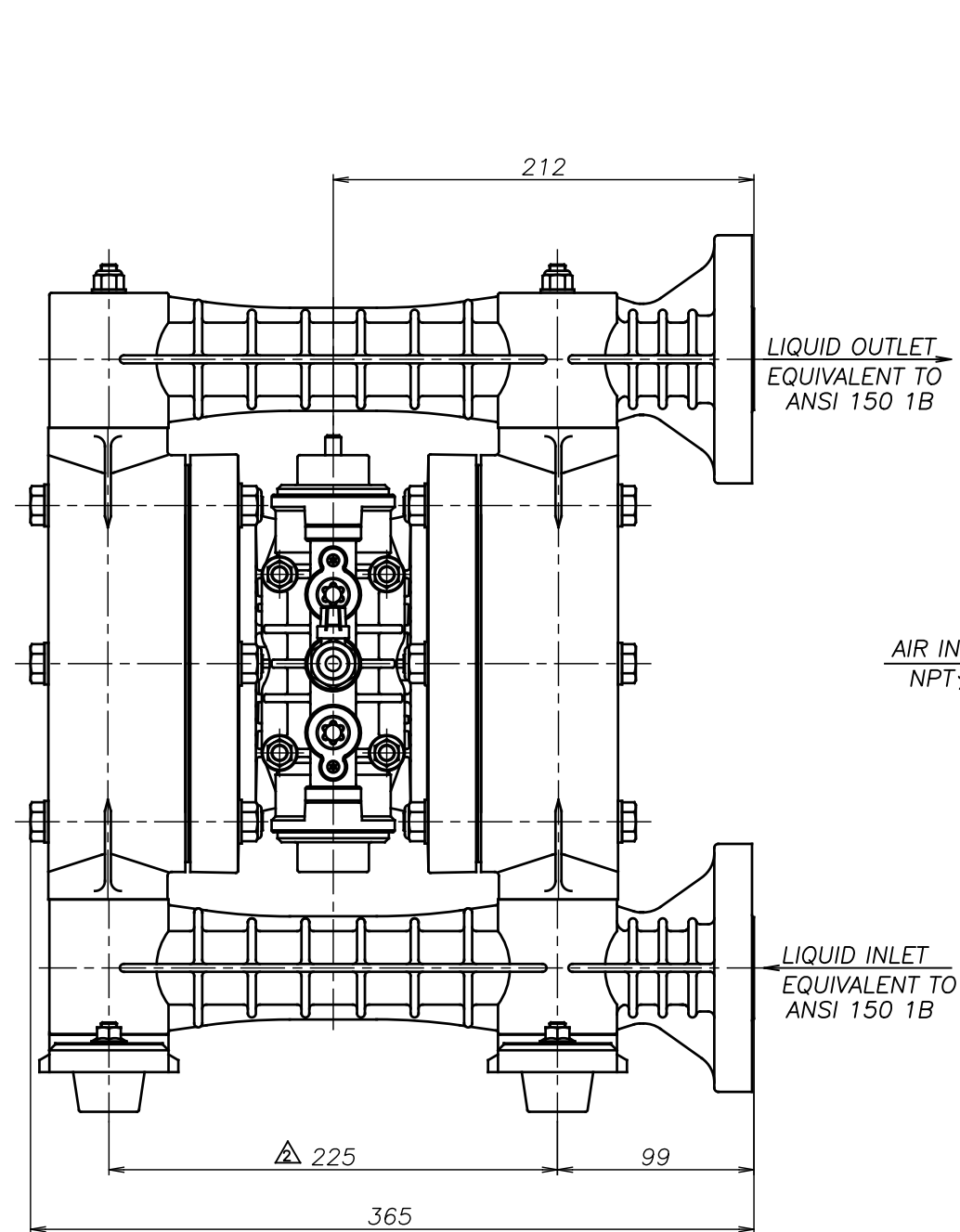

△TC-X250VSA	THIRD ANG. PROJ.	DWG.NO.
SCALE Free		1H00113YN-C
△TC-X250VHA	THIRD ANG. PROJ.	DWG.NO.
SCALE Free		1H00112YN-C
△TC-X250VTA	THIRD ANG. PROJ.	DWG.NO.
SCALE Free		1H00111YN-C
△TC-X250VVA	THIRD ANG. PROJ.	DWG.NO.
SCALE Free		1H00110YN-C
△TC-X250VEA	THIRD ANG. PROJ.	DWG.NO.
SCALE Free		1H00109YN-C

APP'D BY	'20. 8.18	S.Murata	THE DWG. OF:	
CHECKED BY	'20. 8.18	K.Nakano	ダイヤフラムポンプアセンブリ	
DRAWN BY	'20. 8.18	K.Nakada	DIAPHRAGM PUMP ASSEMBLY	
YTS CORPORATION JAPAN			△TC-X250VEA	
			THIRD ANG. PROJ.	DWG.NO.
			SCALE Free	1H00109YN-C