

SYM	DWG.NO	CHANGE NO	DATE	REV'D BY
△	ALL	1HE0017	'16. 2.23	K.Nakada
△	ALL	1BE0005	'19.10.28	K.Nakada
△	ALL	1BE0006 異記訂正	'20. 6.23	K.Nakada

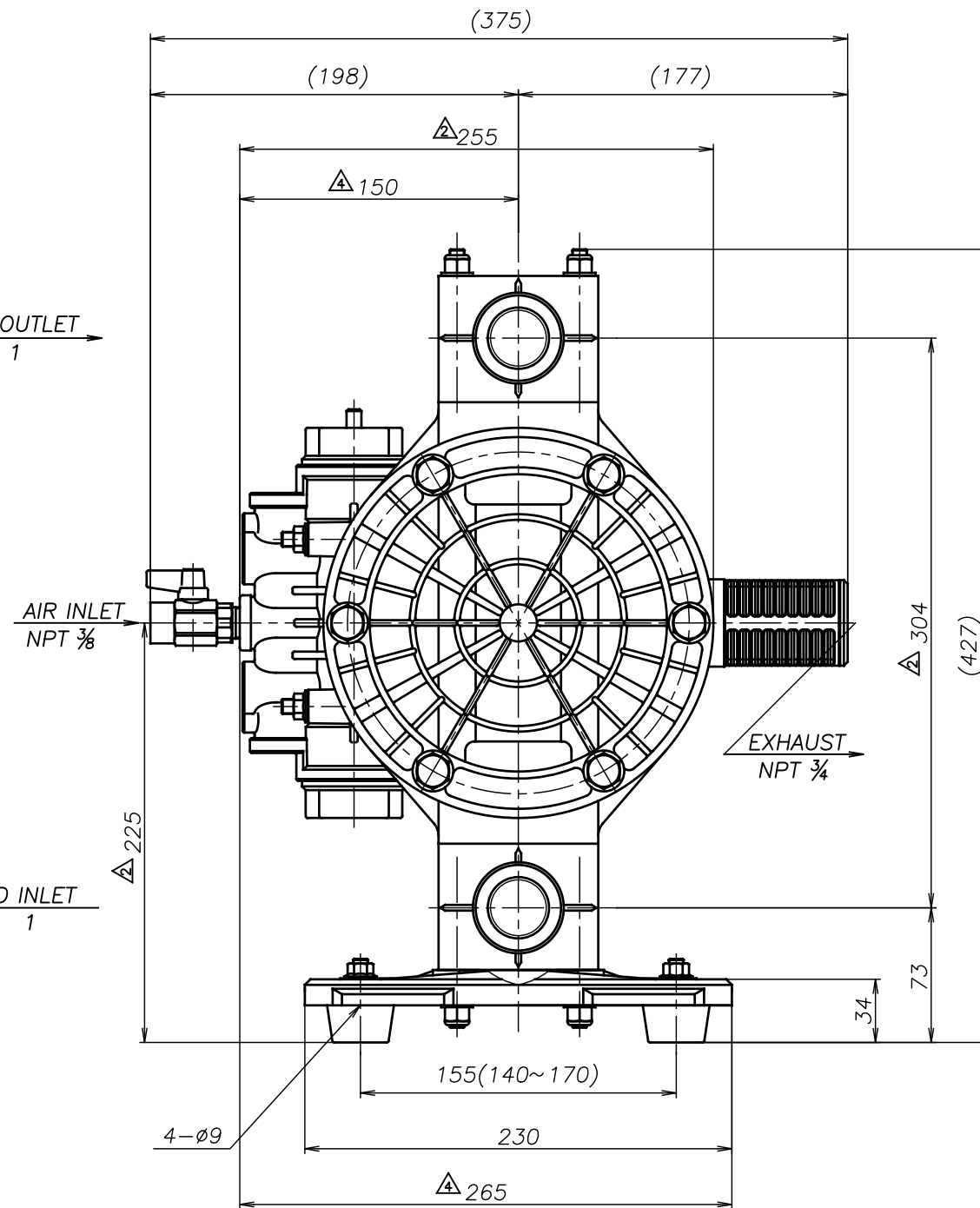
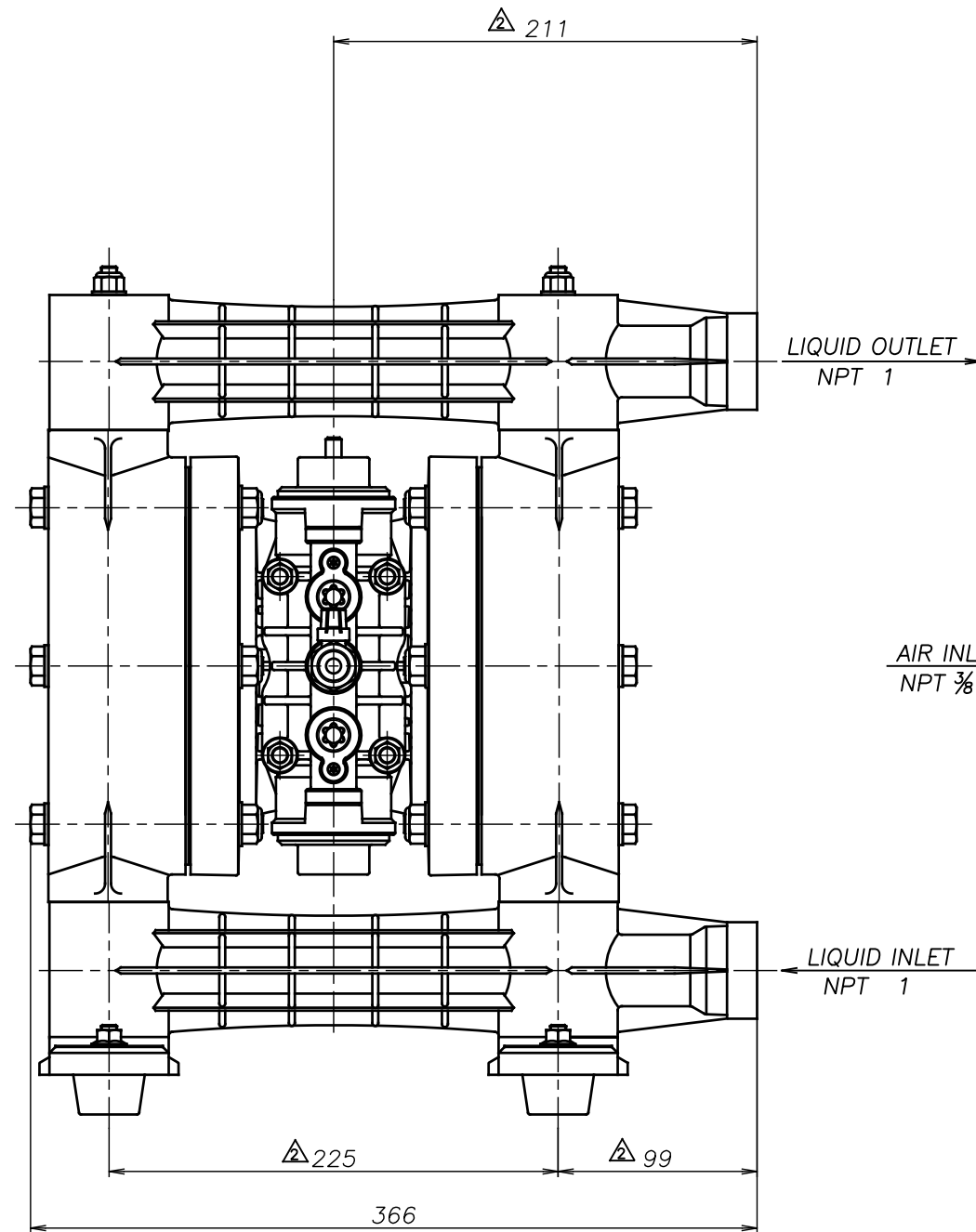

△TC-X250VSN	THIRD ANG. PROJ.	DWG.NO.
	SCALE	Free
		1H00108YN-E
△TC-X250VHN	THIRD ANG. PROJ.	DWG.NO.
	SCALE	Free
		1H00107YN-E
△TC-X250VTN	THIRD ANG. PROJ.	DWG.NO.
	SCALE	Free
		1H00106YN-E
△TC-X250VWN	THIRD ANG. PROJ.	DWG.NO.
	SCALE	Free
		1H00105YN-E

APP'D BY	'20. 8.18	S.Murata	THE DWG. OF:
CHECKED BY	'20. 8.18	K.Nakano	ダイヤフラムポンプアセンブリ
DRAWN BY	'20. 8.18	K.Nakada	DIAPHRAGM PUMP ASSEMBLY
			△TC-X250VEN
			THIRD ANG. PROJ.
			DWG.NO.
			SCALE
			Free
			1H00104YN-E

YTS CORPORATION JAPAN