

SYM	DWG.NO	CHANGE NO	DATE	REV'D BY
△	ALL	1ME0003	'15. 4.15	K.Nakada
△	ALL	1BE0005	'19.10.28	K.Nakada
△	ALL	1BE0006 異記訂正	'20. 6.23	K.Nakada

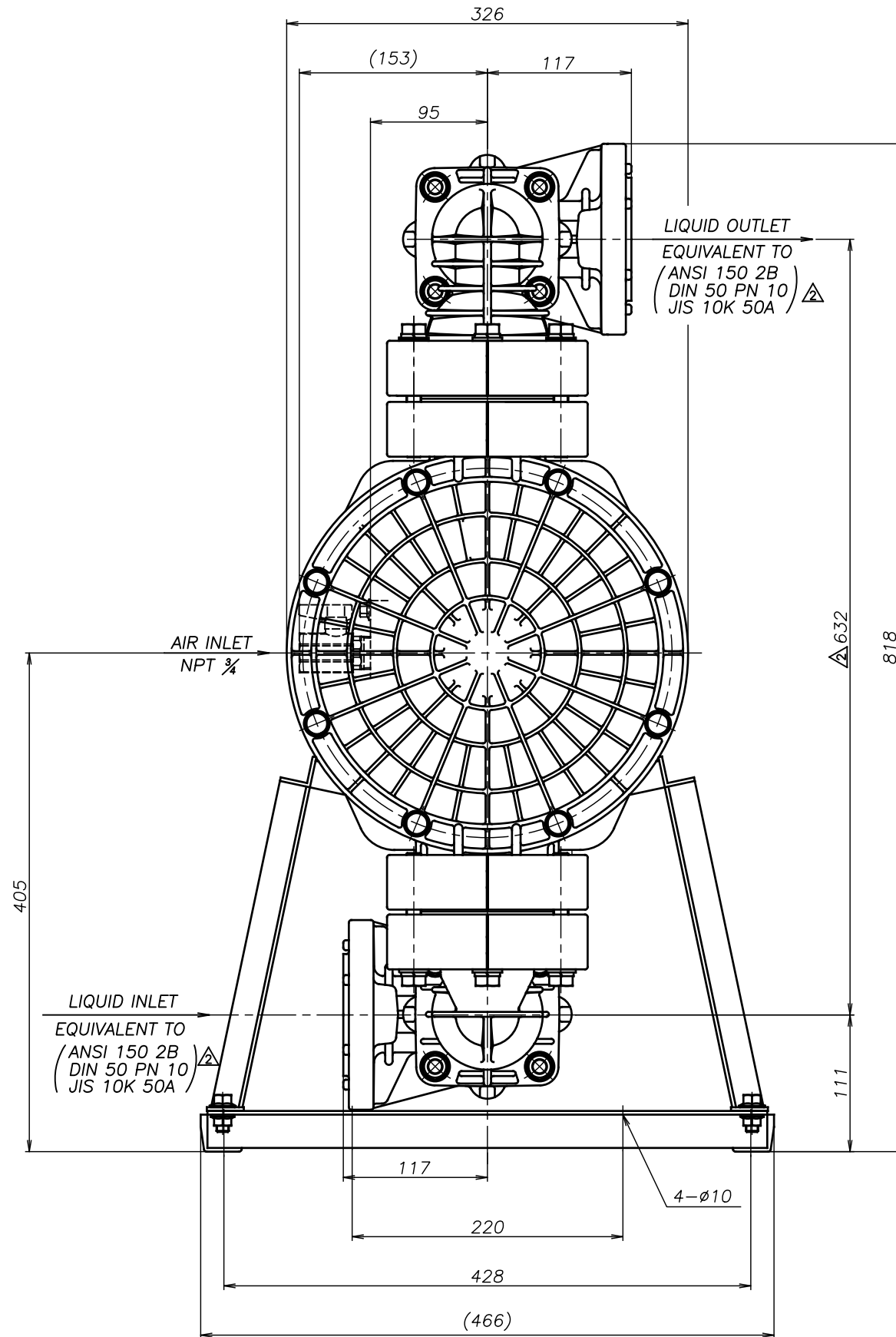
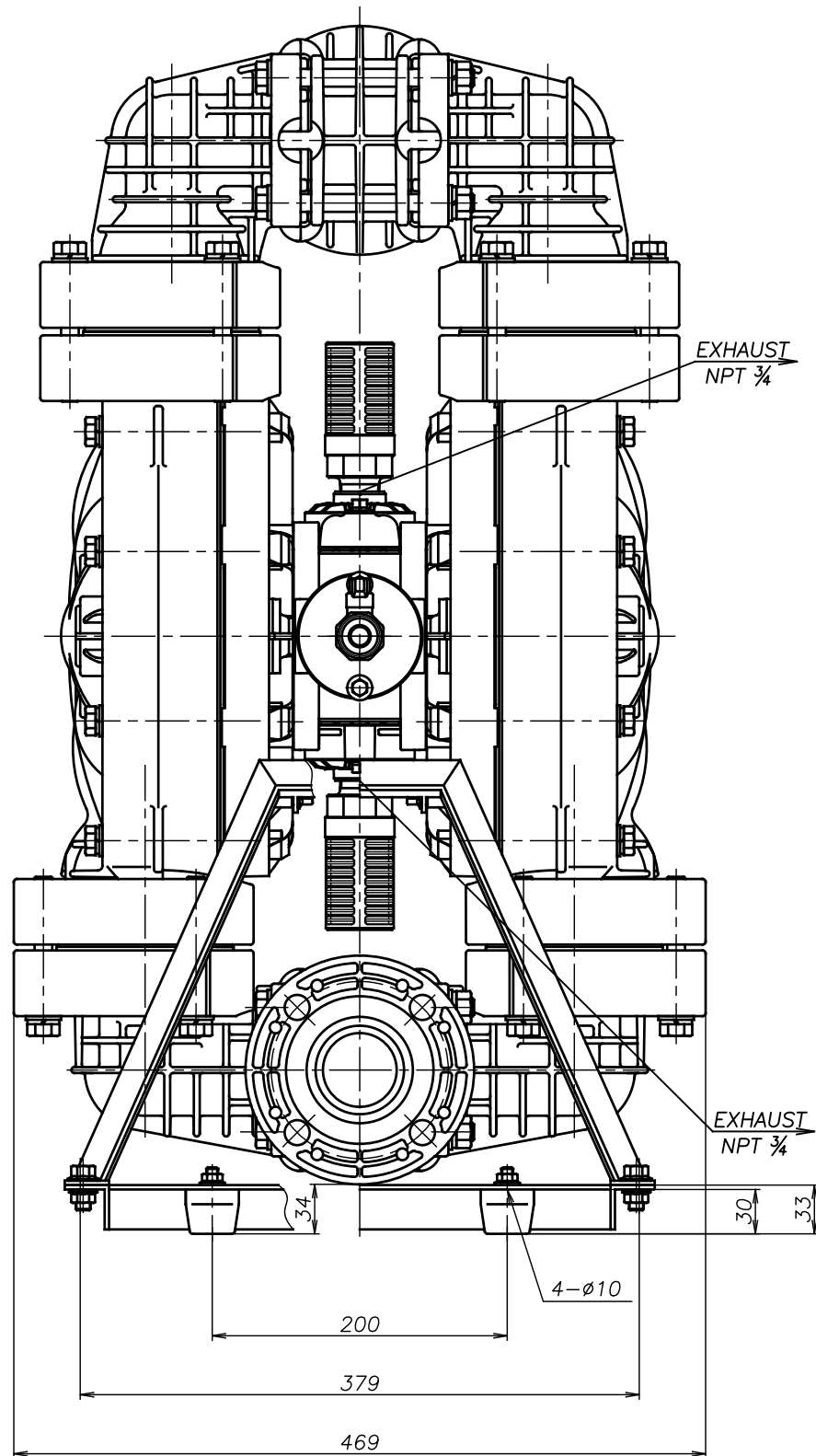

△TC-X500GSA-M	THIRD ANG. PROJ.	DWG.NO.
	SCALE	Free 1M00096YN-C
△TC-X500GHA-M	THIRD ANG. PROJ.	DWG.NO.
	SCALE	Free 1M00095YN-C
△TC-X500GTA-M	THIRD ANG. PROJ.	DWG.NO.
	SCALE	Free 1M00094YN-C
△TC-X500GVA-M	THIRD ANG. PROJ.	DWG.NO.
	SCALE	Free 1M00093YN-C
△TC-X500GEA-M	THIRD ANG. PROJ.	DWG.NO.
	SCALE	Free 1M00092YN-C
△TC-X500GNA-M	THIRD ANG. PROJ.	DWG.NO.
	SCALE	Free 1M00091YN-C

APP'D BY	'20. 8.18 S.Murata	THE DWG. OF:
CHECKED BY	'20. 8.18 K.Nakano	ダイヤフラムポンプアセンブリ
DRAWN BY	'20. 8.18 K.Nakada	DIAPHRAGM PUMP ASSEMBLY
		△TC-X500GCA-M
		THIRD ANG. PROJ.
		DWG.NO.
		SCALE
		Free 1M00090YN-C

YTS Co., Ltd JAPAN