

SYM	DWG.NO	CHANGE NO	DATE	REV'D BY
△	ALL	1ME0006	'16. 2.23	K.Nakada
△	ALL	1BE0005	'19.10.28	K.Nakada
△	ALL	1BE0006 異記訂正	'20. 6.23	K.Nakada

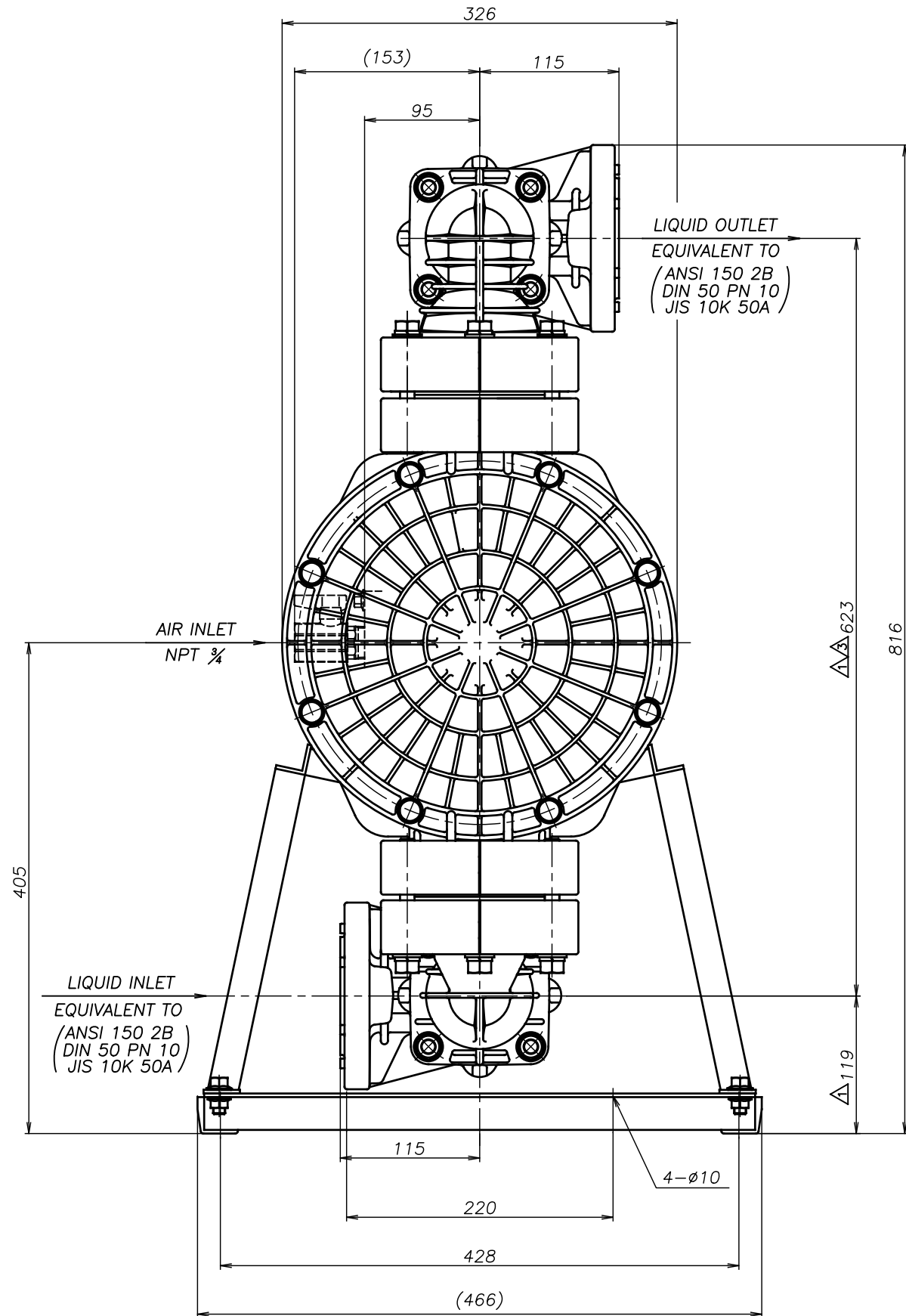
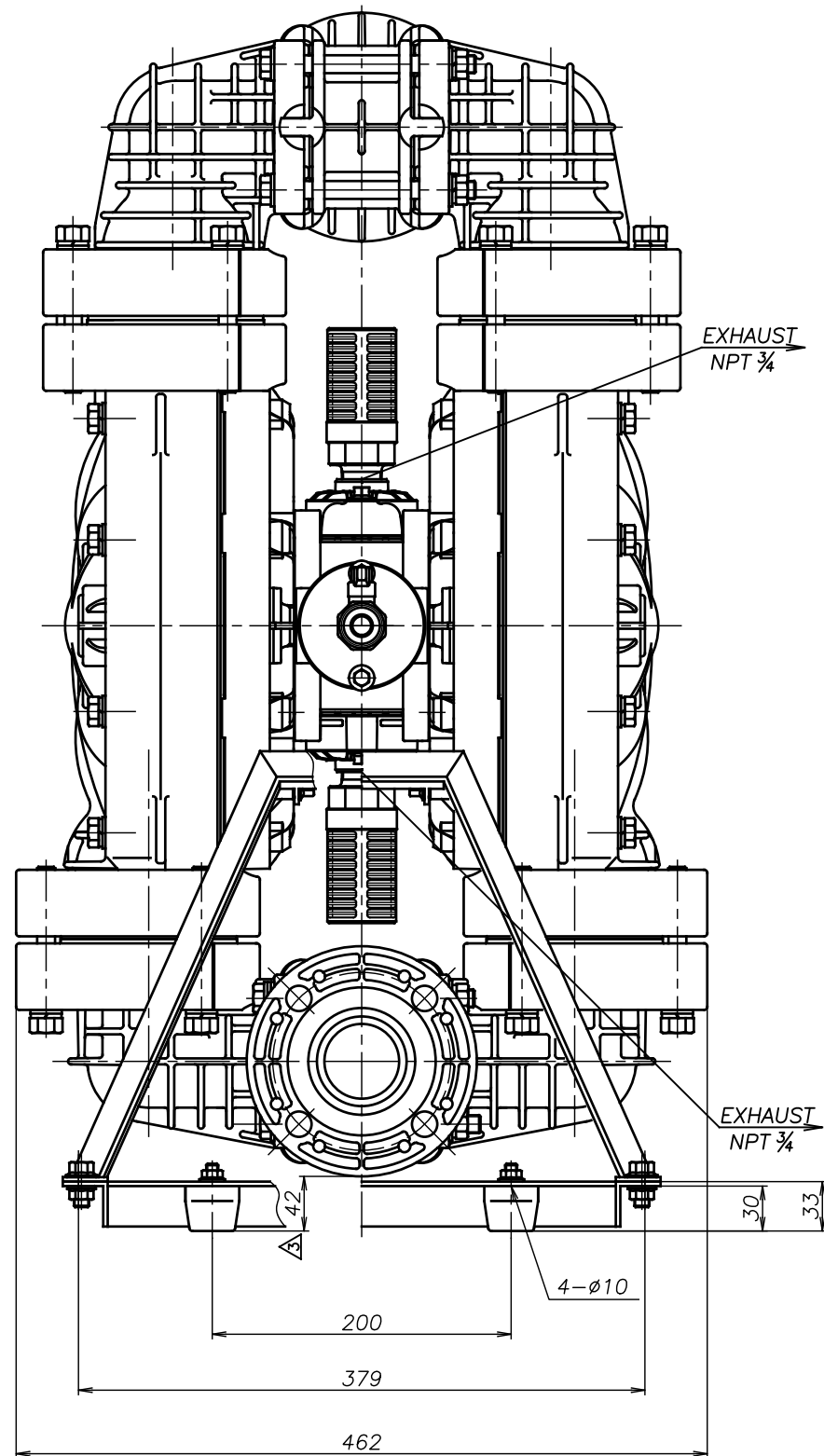

△TC-X500VSA-M	THIRD ANG. PROJ.	DWG.NO.
	SCALE	Free 1M00101YN-D
△TC-X500VHA-M	THIRD ANG. PROJ.	DWG.NO.
	SCALE	Free 1M00100YN-D
△TC-X500VTA-M	THIRD ANG. PROJ.	DWG.NO.
	SCALE	Free 1M00099YN-D
△TC-X500VA-M	THIRD ANG. PROJ.	DWG.NO.
	SCALE	Free 1M00098YN-D

APP'D BY	'20. 8.18	S.Murata	THE DWG. OF:
CHECKED BY	'20. 8.18	K.Nakano	ダイアフラムポンプアセンブリ
DRAWN BY	'20. 8.18	K.Nakada	DIAPHRAGM PUMP ASSEMBLY
			△TC-X500VEA-M
			THIRD ANG. PROJ.
			DWG.NO.
			SCALE
			Free 1M00097YN-D

YTS Co., Ltd JAPAN